



Ontwerpen voor nieuwe productietechnieken

Bas Keijsers

Technical Manager Manufacturing

Hype or Reality?



Gartner's hype cycle

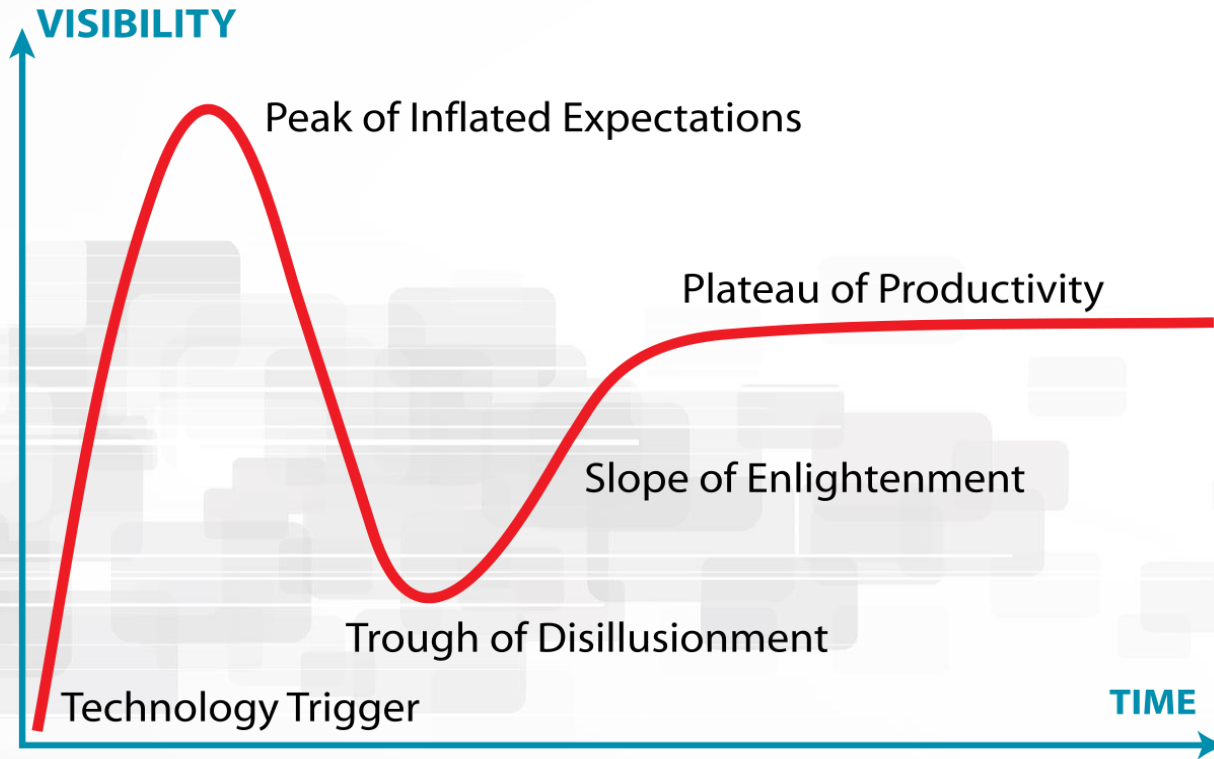

Buy or bye?

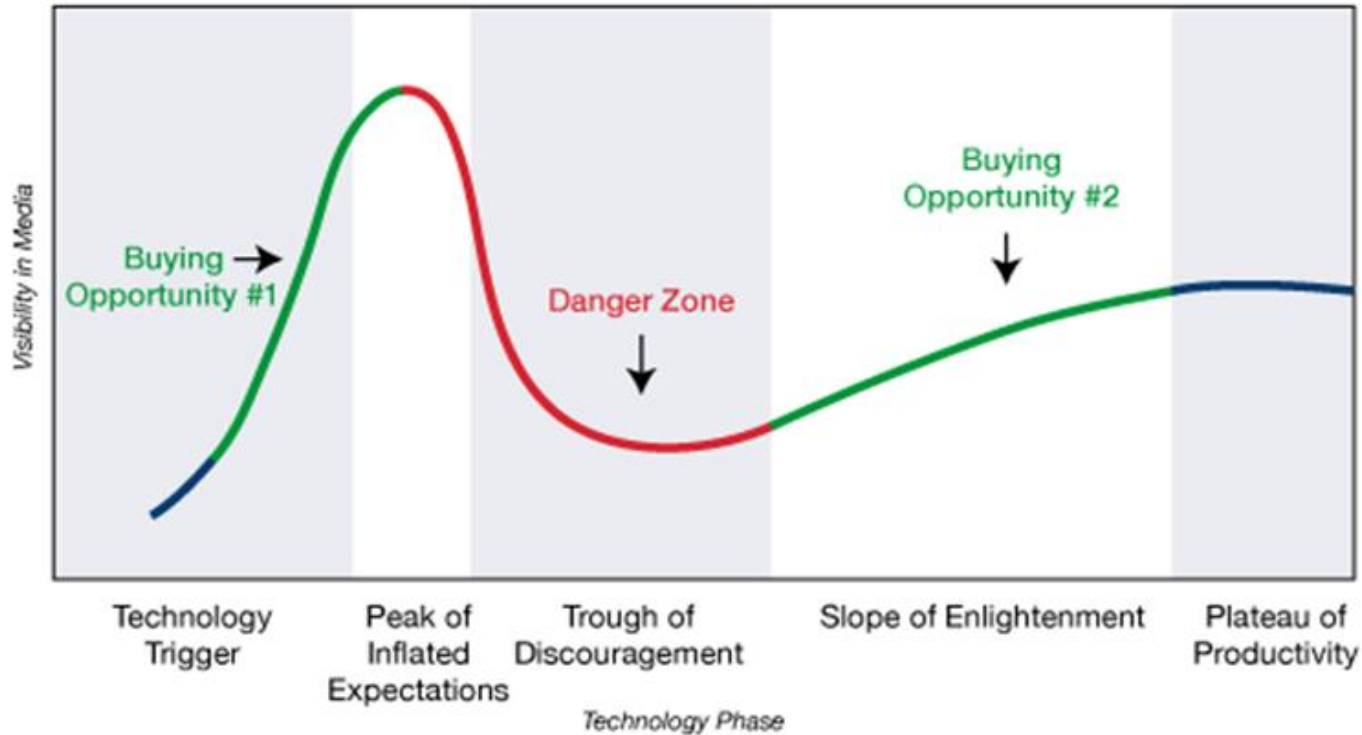

4D Printing

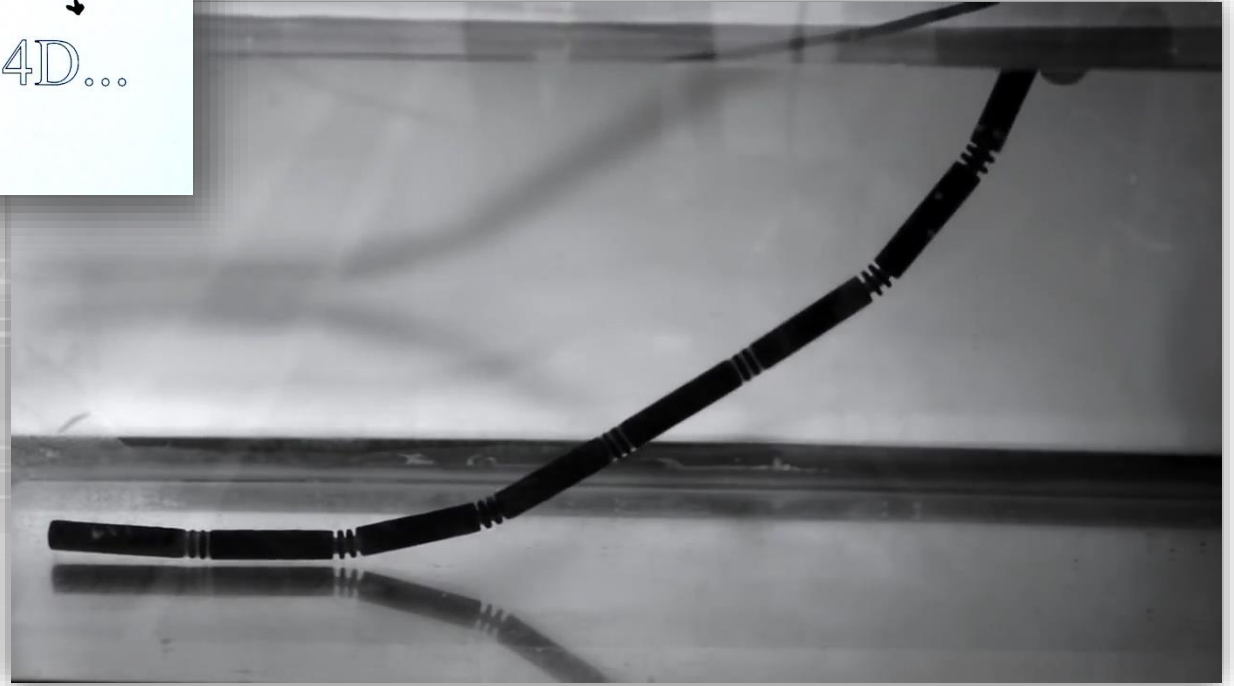
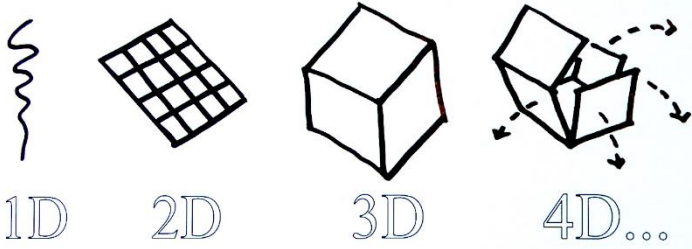



MPA Metal Powder Application

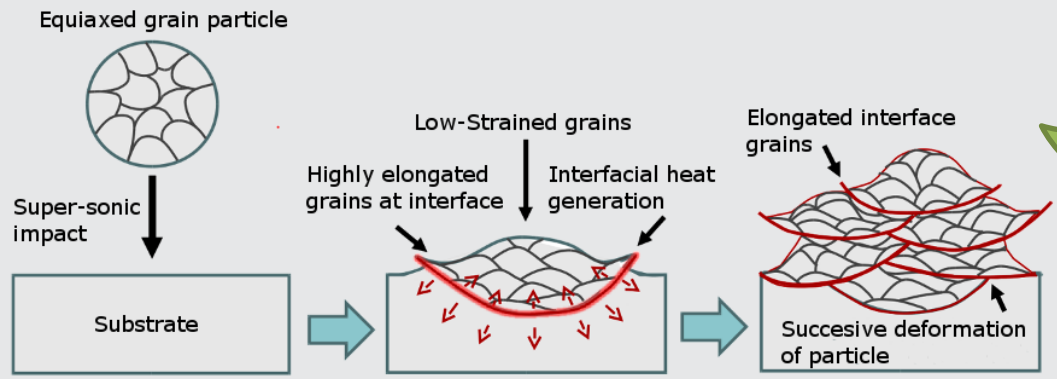
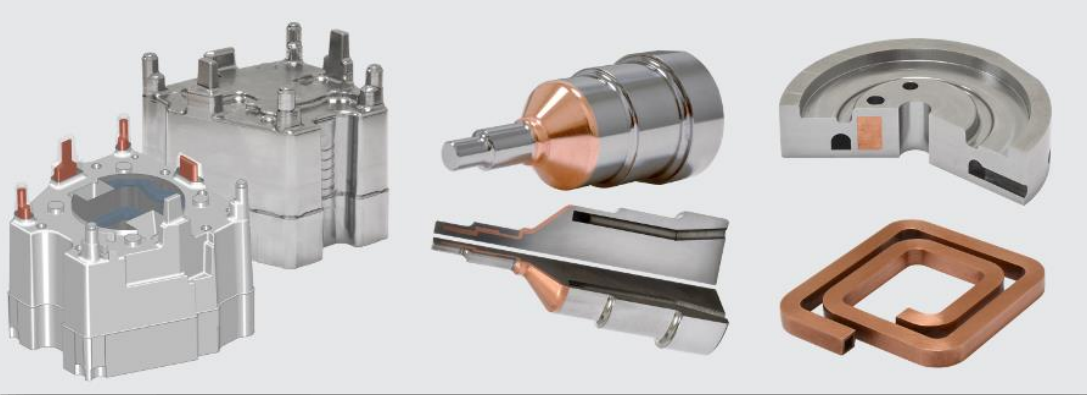

10 GPa
1000°C

MIM - Metal Injection Molding

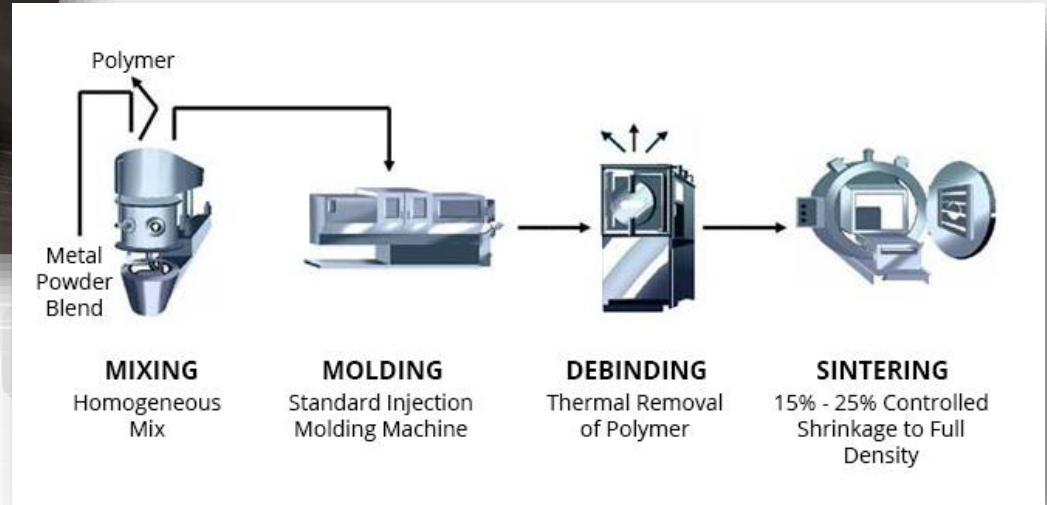

FDM

Fused Deposition Modeling

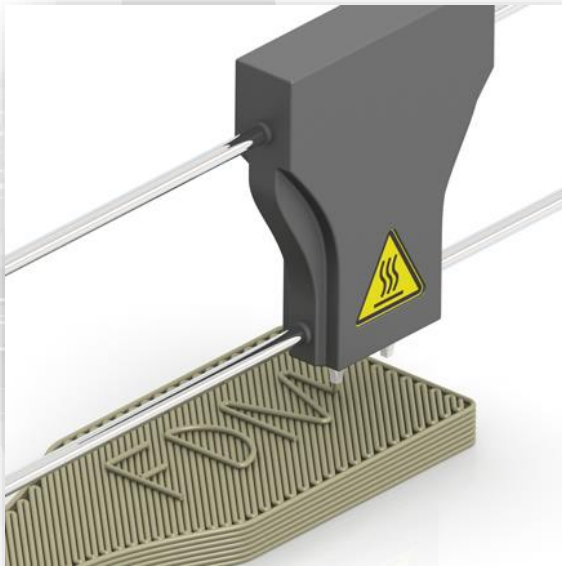

SLS

Selective Laser Sintering

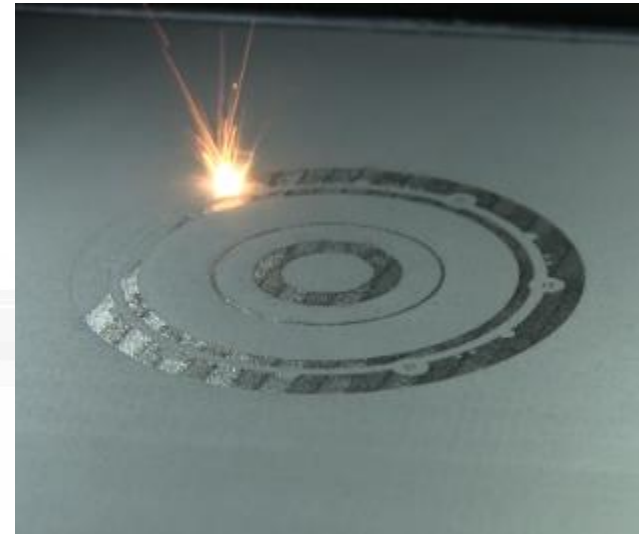

SLA

Stereolithography

ADAM

Atomic
Diffusion
Additive
Manufacturing



Glass printing

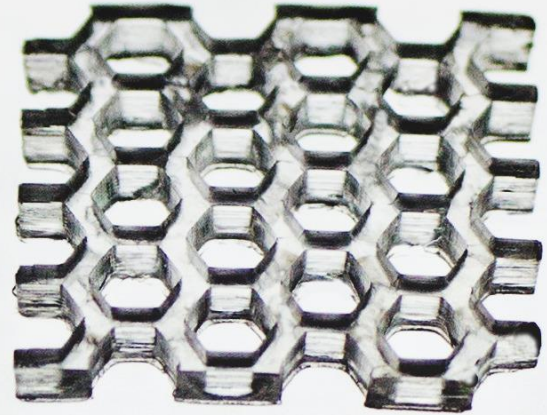

Ceramic printing



FRP3D

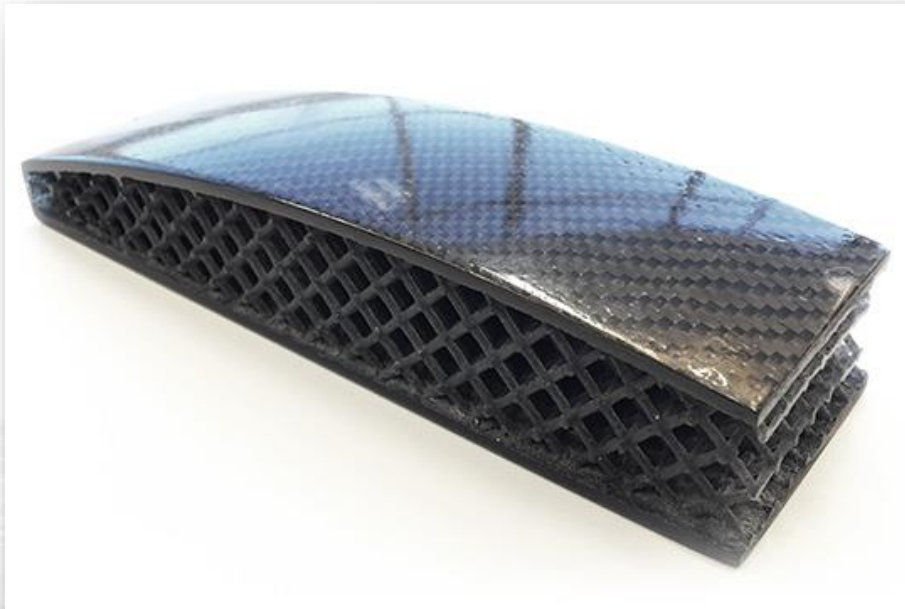

Hybrid Machining



Let's get real

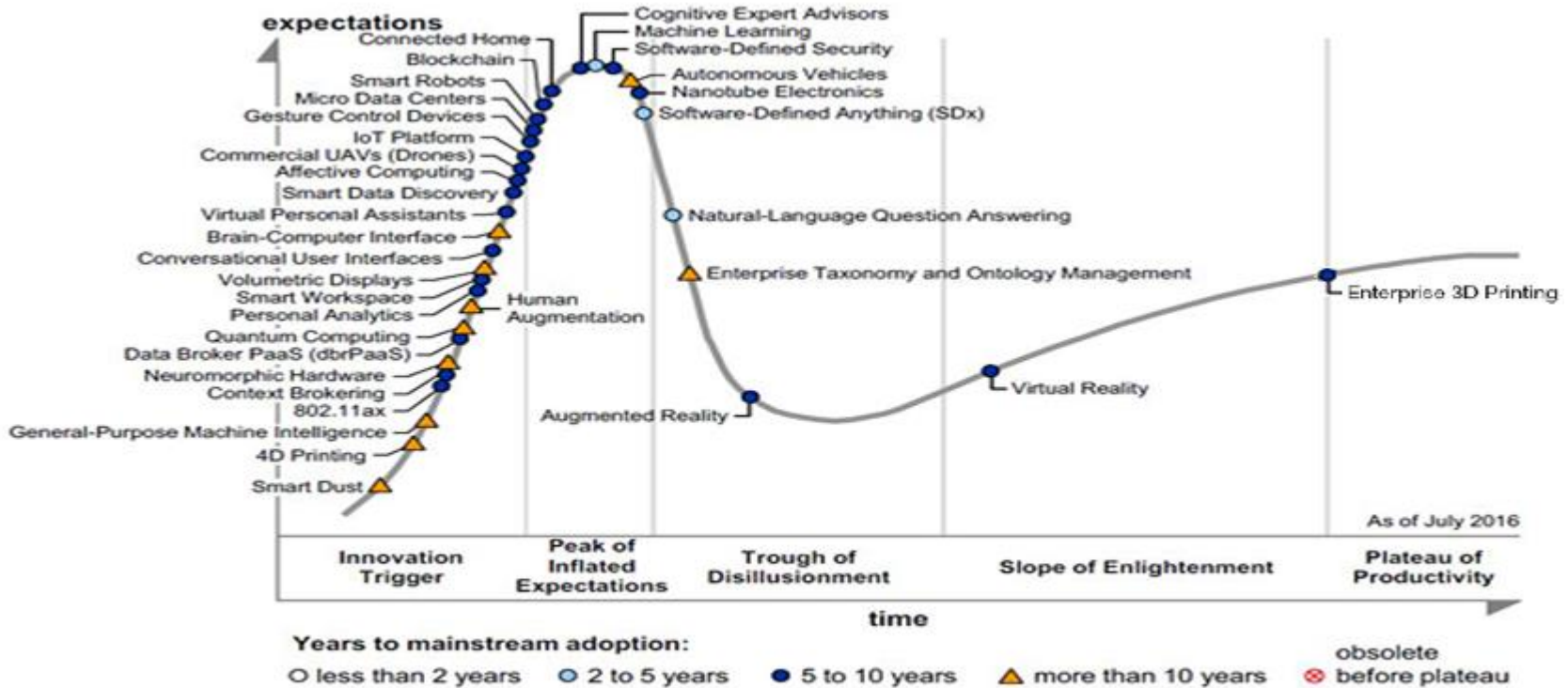

Source: Gartner (July 2016)

FDM printing

3d printer - Google zoek

Veilig | https://www.google.nl/search?q=3d+printer&oq=3d+printer&aqs=chrome..69i57j0l5.2743j0j4&sourceid=chrome&ie=UTF-8#tbs=vw:mr:1,pric

3d printer

Alle Afbeeldingen Maps Shopping Meer Instellingen













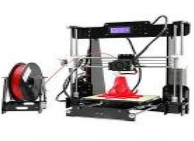
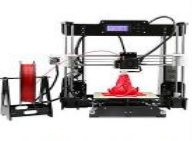

Alle filters wissen Tot € 300 Sorteren: Standaard Weergeven: Raster Mijn shoppinglijst (0)

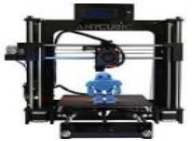
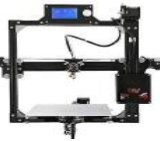
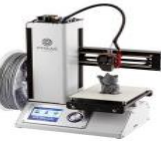
Luw locatie: 's-Hertogenbosch

Alleen tonen Nieuwe artikelen

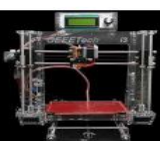
Prijs - Wissen Tot € 300 € tot € 300 Zoeken

Verkoper 3DWare bol.com Foto Meinema Megekko.nl wehkamp Meer

 <p>XYZprinting Da Vinci Mini 3D Printer € 295,00 bij 3D Ninja B.V.</p>	 <p>Drukbed-uitbreiding/Velleman K8200 Geschikt voor: Velleman K8200 € 139,00 bij 2 winkels</p>	 <p>da Vinci Mini W € 295,00 bij 4 winkels ★★★★★ (45)</p>	 <p>anet a3 hoge precisie hoge kwaliteit fdm desktop 3D-printer #00001 € 260,05 bij LightInTheBox</p>	 <p>anet a8-b hoge precisie hoge kwaliteit fdm desktop diy 3d printer ... € 130,36 bij LightInTheBox</p>	 <p>anet a8 FDM desktop diy 3D-printer #00001 € 130,36 bij LightInTheBox</p>
 <p>anet a8 nieuwe versie fdm desktop diy 3d printer (adjustable ... € 160,04 bij LightInTheBox</p>	 <p>3D-printer diy kit onderwijs Prusa 3 hoge precisie #00002 € 173,04 bij LightInTheBox</p>	 <p>3d printing anet a2-b hoge precisie hoge kwaliteit fdm desktop diy ... € 145,30 bij LightInTheBox</p>	 <p>PrimaCreator P120 Standaard 3D Printer € 299,00 bij 3D Ninja B.V.</p>	 <p>CoLiDo zelfbouw-3D-printer € 294,30 bij 123-3D.nl ★★★★★ (1)</p>	 <p>Flashforge MK10 Dual Extruder Set Standaard 3D Printer € 149,00 bij 3D Ninja B.V.</p>
 <p>da Vinci miniMaker Special Edition Red 3D Printer € 259,00 bij 3DWare</p>	 <p>geeetech macreator 2 desktop ultrahoge precisie plaatwerk 3D ... € 232,01 bij LightInTheBox</p>	 <p>Geeetech i3b 3d printer usb gravure gebied 200 200 180mm abs pla ... € 163,73 bij LightInTheBox</p>	 <p>DaVinci XYZprinting 3FM1WAEU101F Fused Filament Fabrication (FFF) € 254,90 bij 2 winkels ★★★★★ (45)</p>	 <p>Ultimaker Advanced Printing Kit 2 3D Printer € 107,69 bij 3D Ninja B.V.</p>	 <p>XYZprinting Da Vinci 1.0 Pro - Laser Module 3D Printer € 159,00 bij 3D Ninja B.V.</p>

PCB printing

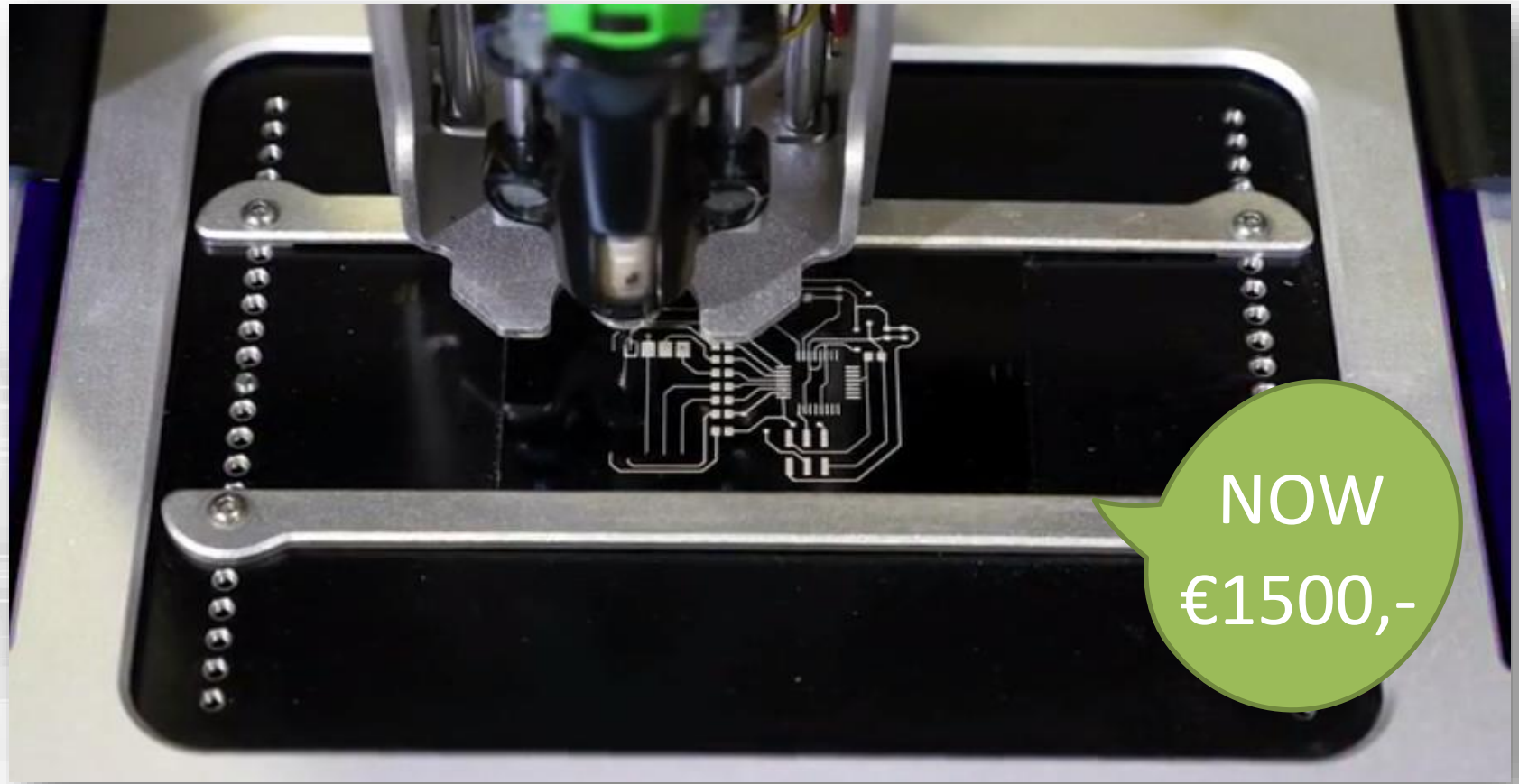

NOW
€1500,-

3D Metal printing



Biomimicry

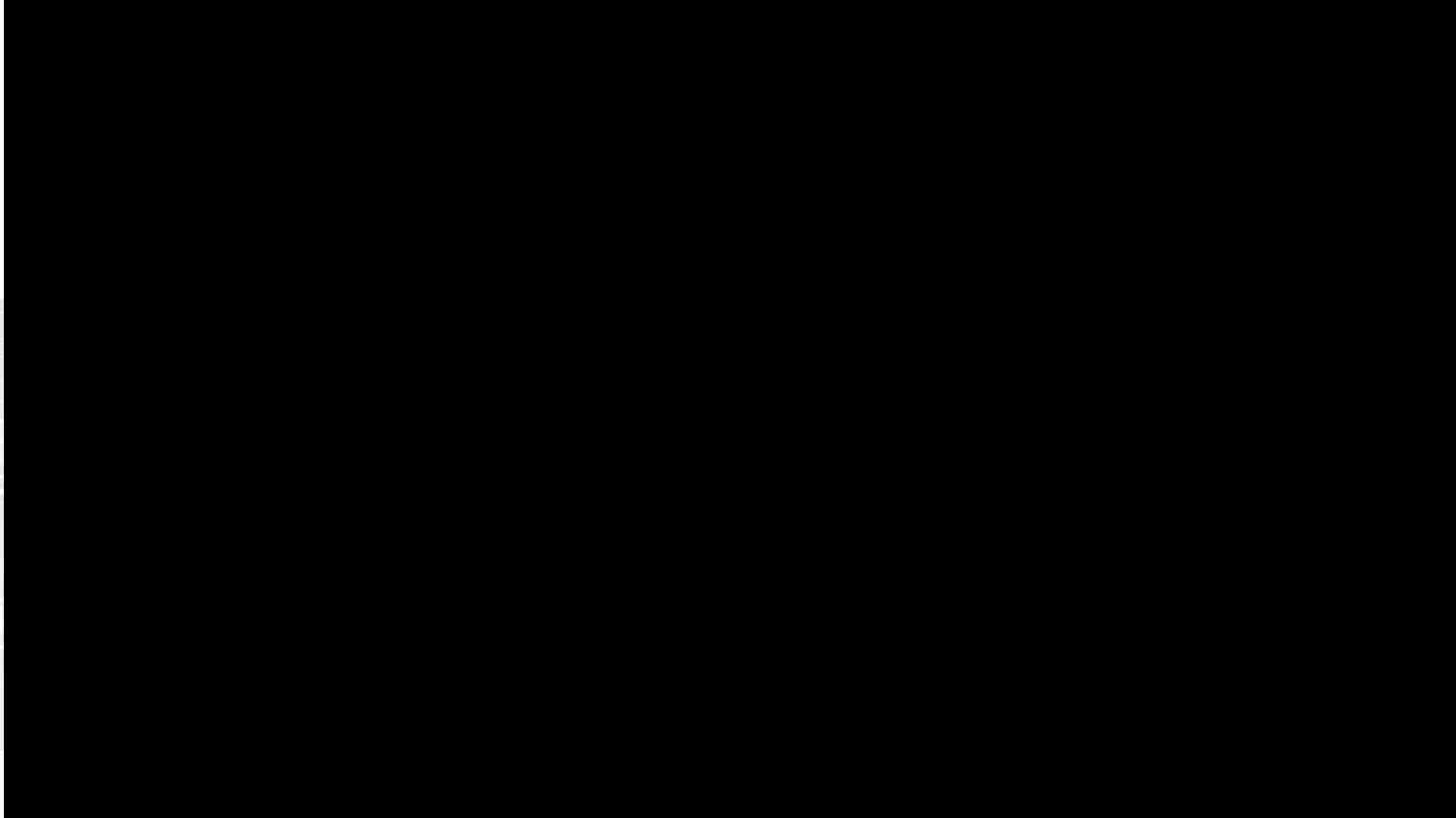

Biomimicry



Biomimicry



Biomimicry



Biomimicry



https://asknature.org/

AskNature - Innovation | x

Veilig | https://asknature.org

BIOLOGICAL STRATEGIES INSPIRED IDEAS RESOURCES COLLECTIONS

JOIN SIGN IN

ASKNATURE

training

Search powered by algolia

Life on earth presents elegant solutions to many of the challenges that designers and innovators face every day. Explore AskNature to find biological strategies, inspired ideas, and resources relative to your own innovation challenges, so you can begin to emulate the time-tested forms, processes, and systems that already thrive in balance with Earth's complex systems.

- BIOLOGICAL STRATEGIES**
Nature's refined solutions, mapped to your design challenges.
- INSPIRED IDEAS**
Design solutions to human challenges, inspired by biological strategies.
- RESOURCES**
Everything you need to learn and teach about biomimicry and life centered design.
- COLLECTIONS**
Themed clusters of strategies, ideas, and resources, curated by you.

Morphological analysis

Morphological Chart

solutions →

sub functions	'human power'														
	steering														
	transmission														
	surprise														
	learning effect														
	acceleration														
	'human power' 2														
	steering 2														

SolidWorks 3D printing

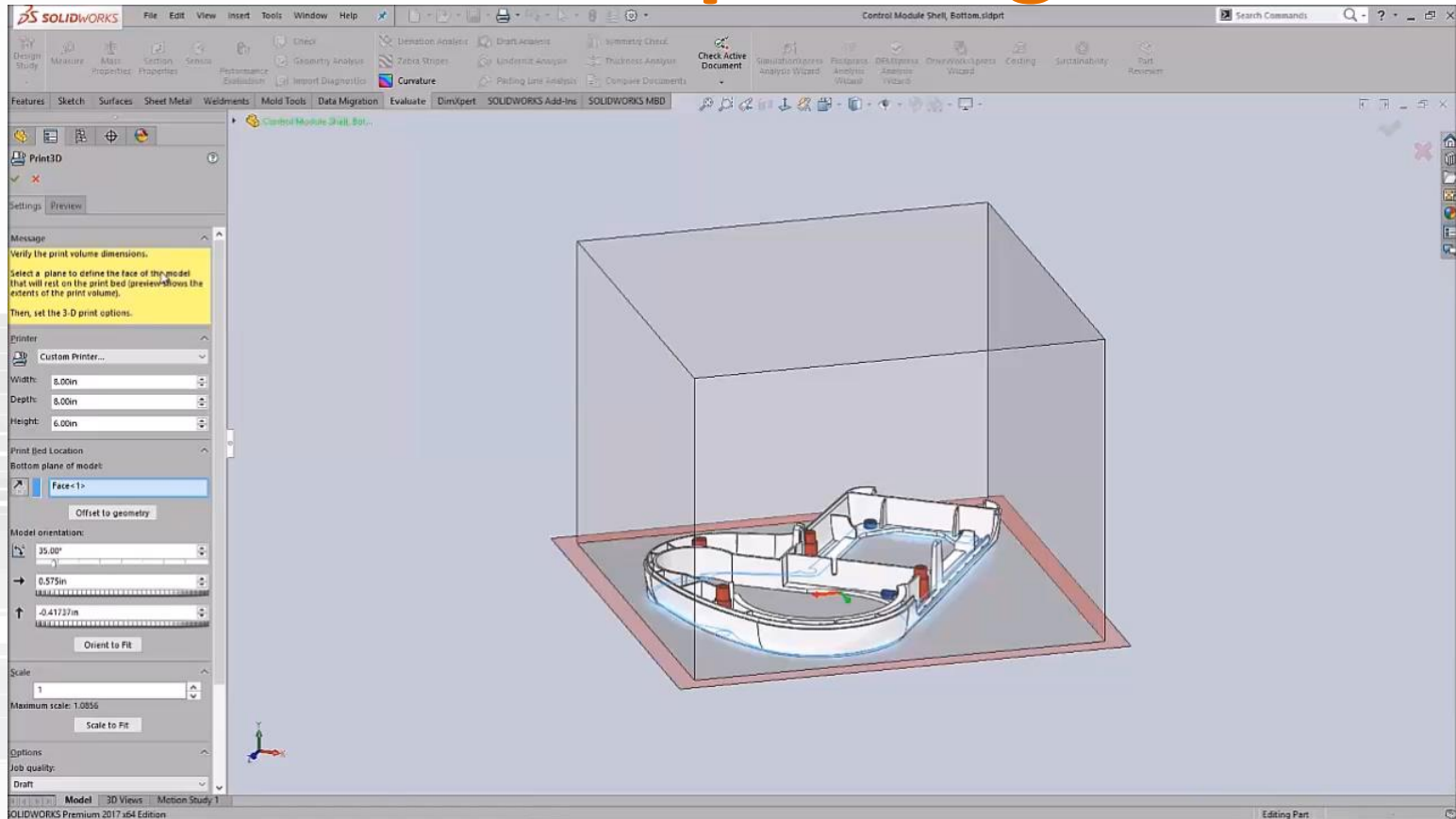

Conformal cooling

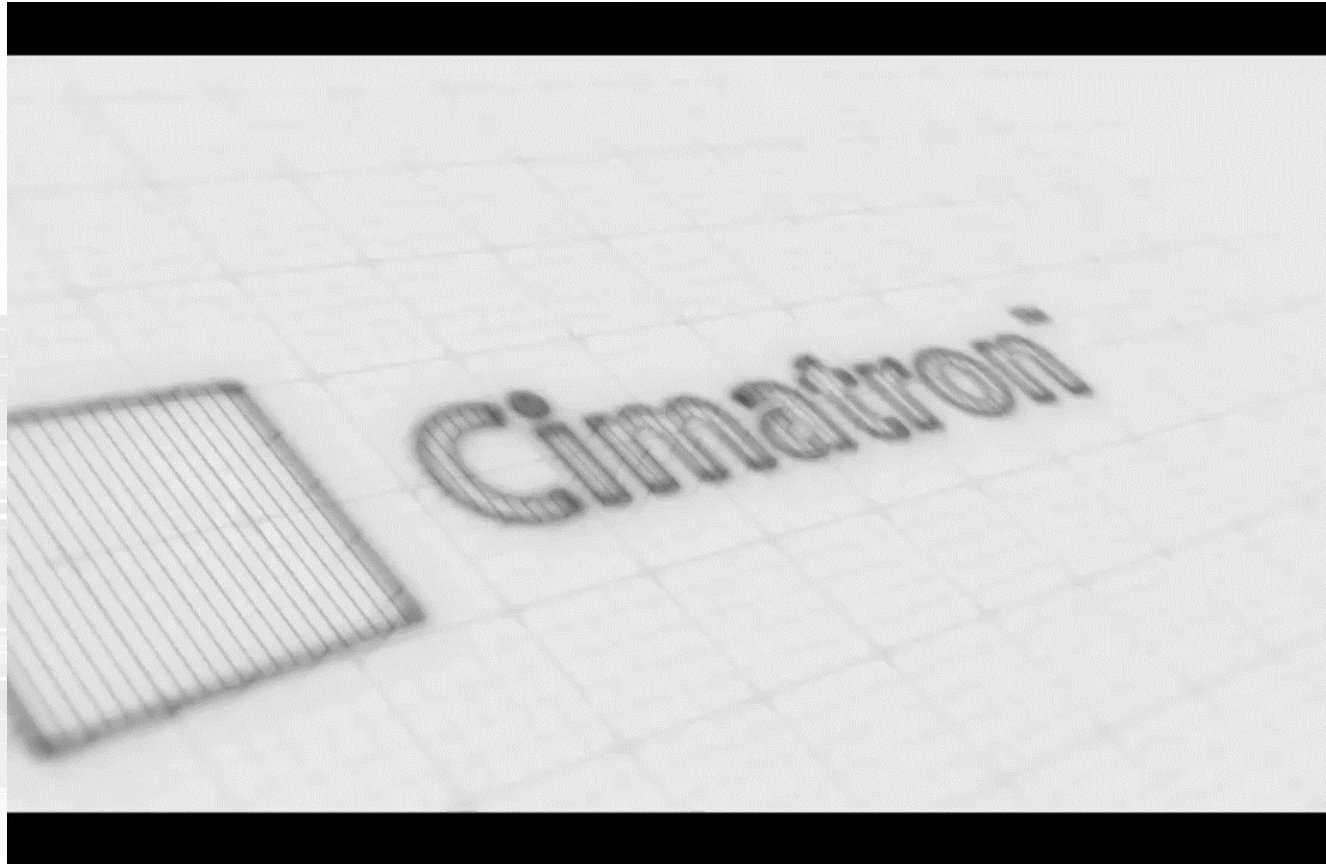

Lattice infill



Lattice infill

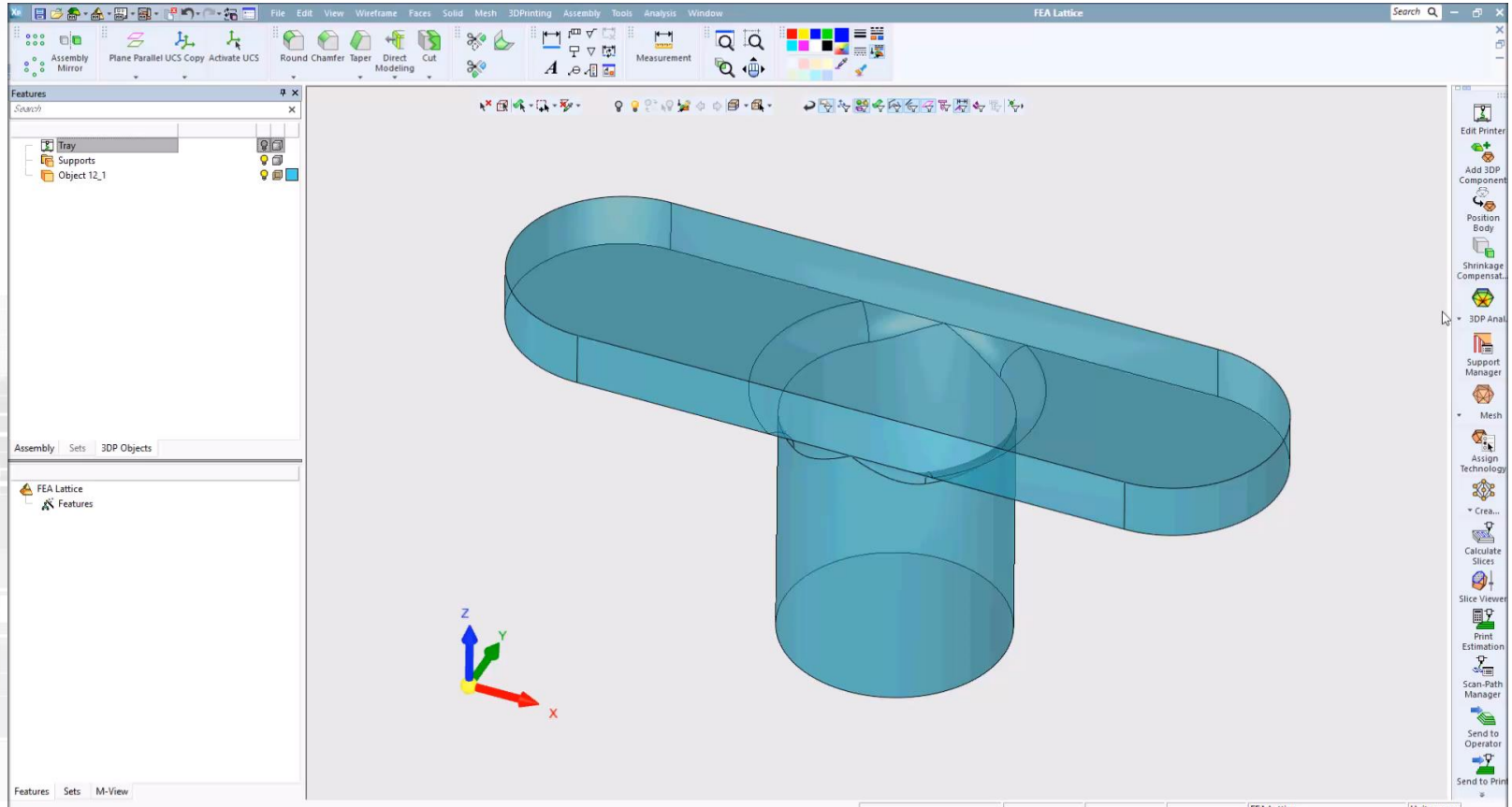

Surface lattice

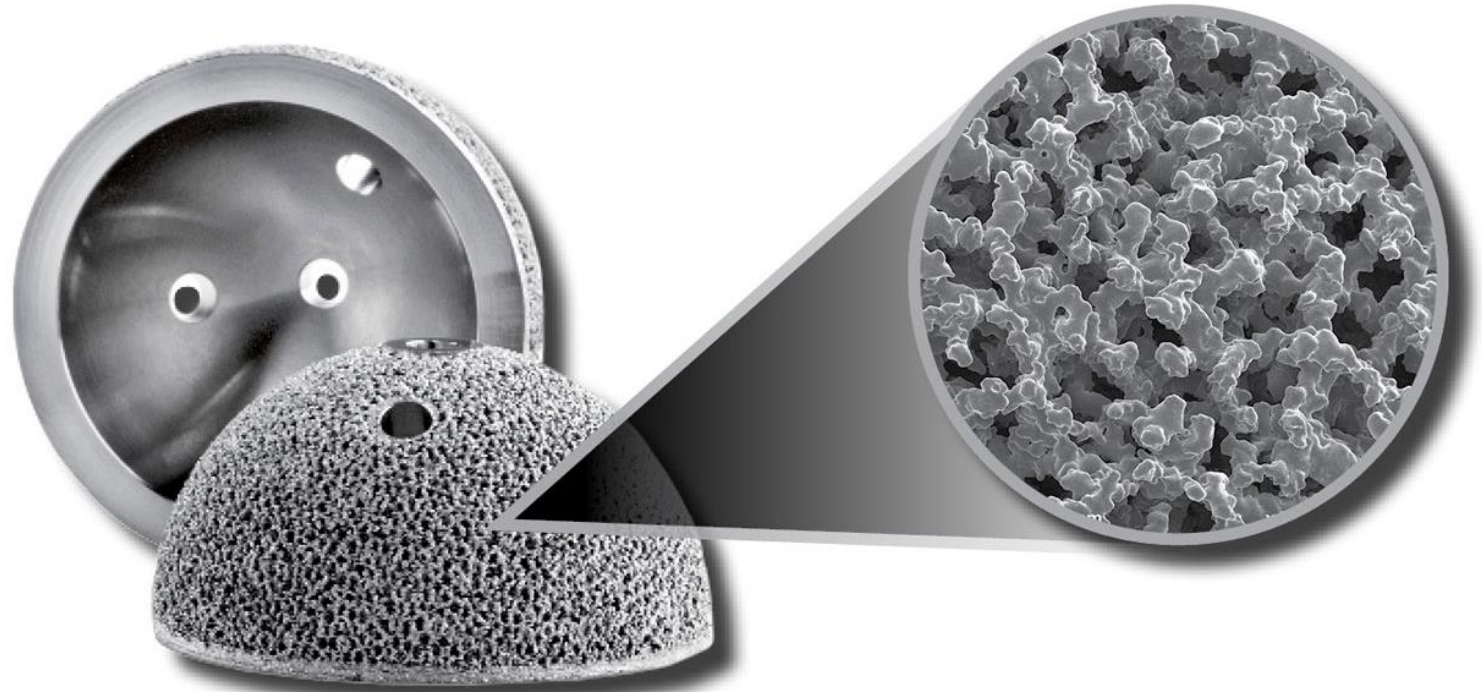

Surface lattice

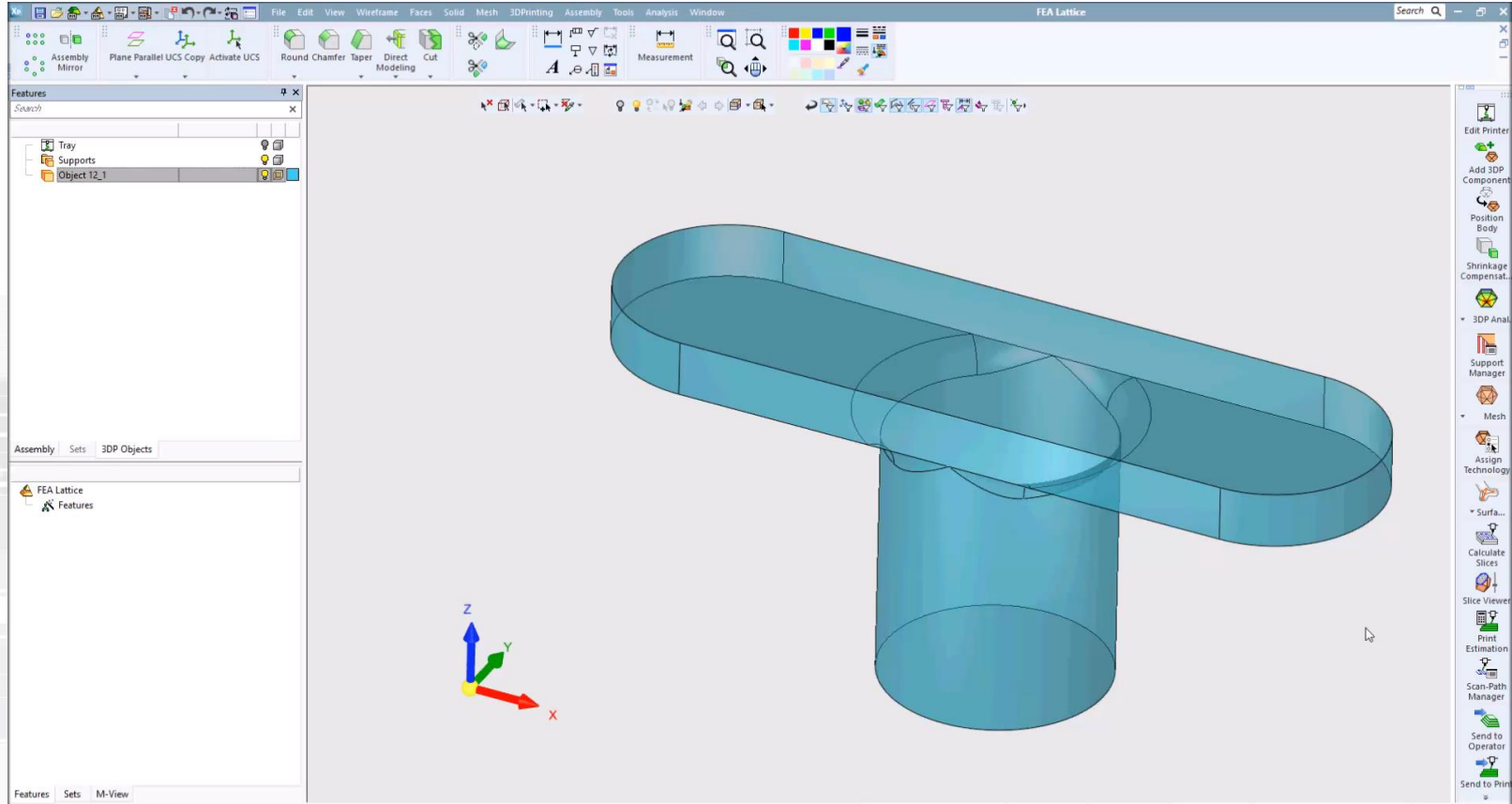

Topology optimization







Thank you!

