



# CONVEYOR BASE TUTORIAL

An Introduction to DriveWorksXpress

# CONTENTS

<b>INTRODUCTION TO DRIVEWORKSXPRESS.....</b>	<b>3</b>
About the Tutorial.....	3
Getting Started .....	4
<b>DRIVEWORKSXPRESS NAVIGATION BAR .....</b>	<b>5</b>
<b>REGISTRATION AND BASIC SETUP .....</b>	<b>6</b>
DriveWorksXpress 2015 Registration.....	6
<b>BASIC SETUP .....</b>	<b>10</b>
Launching DriveWorksXpress .....	10
Create a New Database .....	11
<b>CAPTURING MODELS AND DIMENSIONS .....</b>	<b>12</b>
Capturing SOLIDWORKS Models.....	12
<b>CAPTURING DIMENSIONS AND FEATURES.....</b>	<b>14</b>
Capturing The Conveyor Base.....	16
Capturing The Wheel Base.....	18
Capturing The Adjustable Support .....	19
Capturing The Leg Base .....	20
Capturing The Central Support .....	20
<b>CAPTURING DRAWINGS.....</b>	<b>21</b>
<b>CREATING INPUT FORMS .....</b>	<b>22</b>
Adding Controls.....	22
<b>TEST MODE.....</b>	<b>27</b>
<b>RULES BUILDER .....</b>	<b>28</b>
<b>FILE NAME RULES.....</b>	<b>30</b>
Building Multiple File Name Rules.....	31
Build A Rule for the Wheel Assembly.....	33
Build A Rule for the Wheel Bolt .....	33
<b>DIMENSION RULES .....</b>	<b>34</b>
<b>RUNNING THE PROJECT.....</b>	<b>36</b>

## INTRODUCTION TO DRIVEWORKSXPRESS

DriveWorksXpress is entry-level Design Automation software included in SOLIDWORKS. It is ideal if the designs and projects you work on are the **Same but Different**. It is widely used in many industries from trailers to conveyors, furniture to machinery, mechanical seals to pressure vessels, windows & doors.

You'll find it already installed and waiting for you to use under the SOLIDWORKS Tools menu. It is ideal for everyday repetitive design tasks. Use it to create multiple variations of SOLIDWORKS Parts, Assemblies and Drawings quickly and accurately.

This DriveWorksXpress tutorial is intended to provide a quick introduction to using DriveWorksXpress.

The Tutorial will show how DriveWorksXpress can:

- Reduce the cost of custom designs
- Create SOLIDWORKS assembly, parts and drawings quickly
- Enhance product quality
- Eliminate or reduce repetitive tasks

Upon successful completion of this tutorial, you will be able to:

- Drive SOLIDWORKS part and assembly geometry with DriveWorksXpress
- Create a DriveWorksXpress input form and link the input fields to the SOLIDWORKS model
- Write rules to configure and run your design projects
- Generate new parts, assemblies and drawings

## ABOUT THE TUTORIAL

In this tutorial, we will be automating the creation of a conveyor base. Imagine you work for a company that designs and manufactures bases for conveyors, where each conveyor base you design is the same but different.

The height, width and depth of the conveyor base can be changed. This means a custom design needs to be produced for each sales enquiry or order. This could take a few hours and be very repetitive for you, the engineer. Time spent creating custom files manually could also delay the company's sales cycle.

However, by using DriveWorksXpress, it is possible to reduce both the lead time and the cost of custom designs to help companies to be more competitive and win more business.



## GETTING STARTED

To begin this tutorial, you will need to download the SOLIDWORKS project files for the conveyor base from the DriveWorksXpress website: [www.driveworksxpess.com](http://www.driveworksxpess.com)

The SOLIDWORKS files are contained within a zipped file.

Ensure you extract the files from this folder before beginning the training.

By following this DriveWorksXpress tutorial you will soon be automating your own designs in SOLIDWORKS.

# DRIVEWORKSXPRESS NAVIGATION BAR

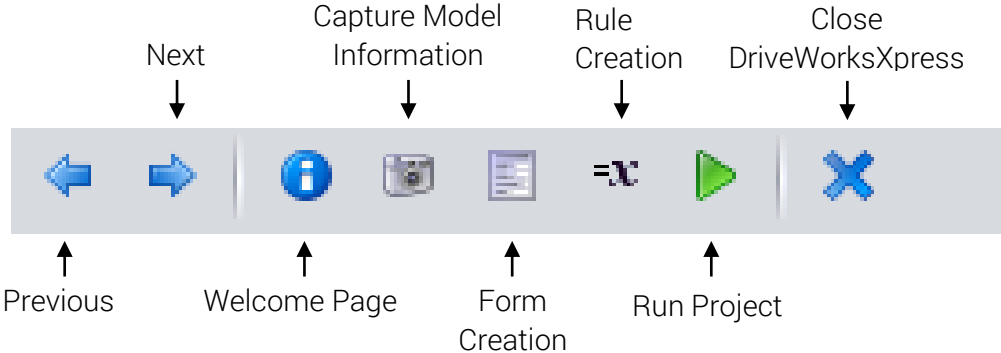

## REGISTRATION AND BASIC SETUP

DriveWorksXpress is included in every seat of SOLIDWORKS. You'll find DriveWorksXpress by navigating to Tools > Xpress Products > DriveWorksXpress in the SOLIDWORKS tool bar.

The first time you use DriveWorksXpress in SOLIDWORKS 2015, you will need to log into your SOLIDWORKS account and register DriveWorksXpress.

If you are using SOLIDWORKS 2014, you can skip directly to Basic Setup.

## DRIVEWORKSXPRESS 2015 REGISTRATION

### STEP 1

You'll need your SOLIDWORKS Serial Number. You can find this by navigating to: Help > About SOLIDWORKS.

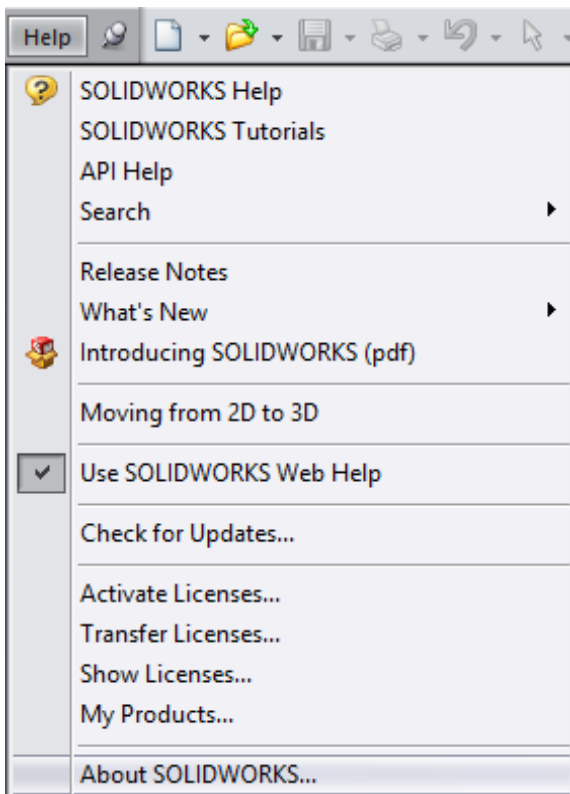

Click 'Show Serial Number' and copy it ready for step two.

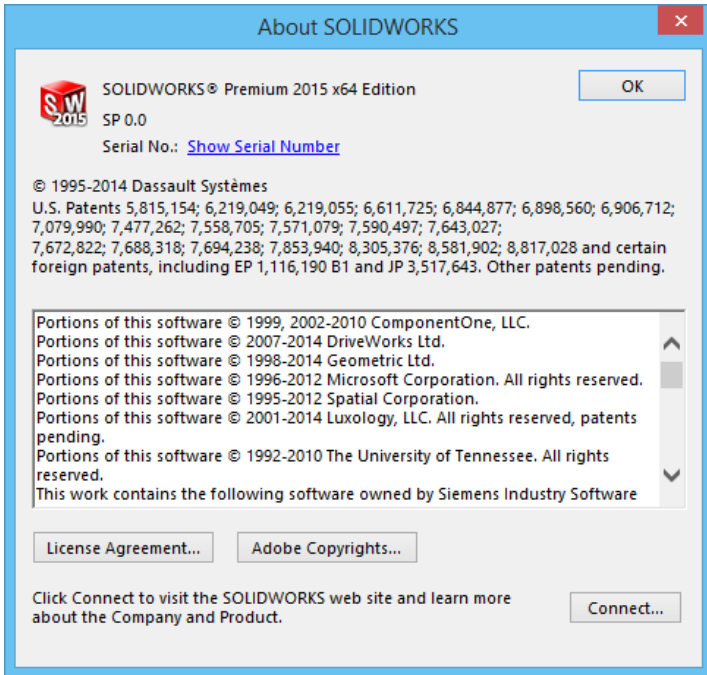

## STEP 2

Once you've got your SOLIDWORKS Serial Number, open DriveWorksXpress.

You will be asked to log into your My SOLIDWORKS account and register DriveWorksXpress with your SOLIDWORKS Serial Number.

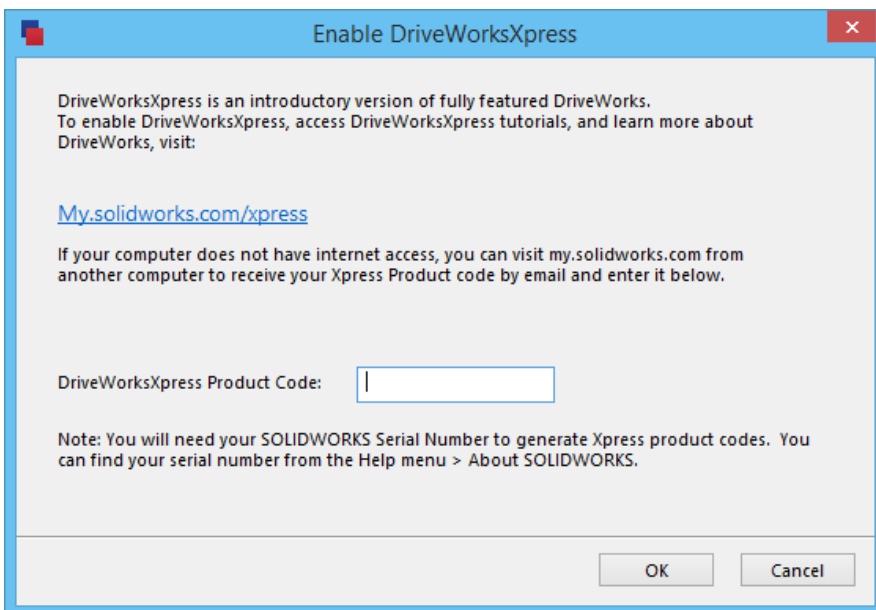

If you don't already have an account, you will need to create one with SOLIDWORKS. This is really easy, just click the link to create an account.

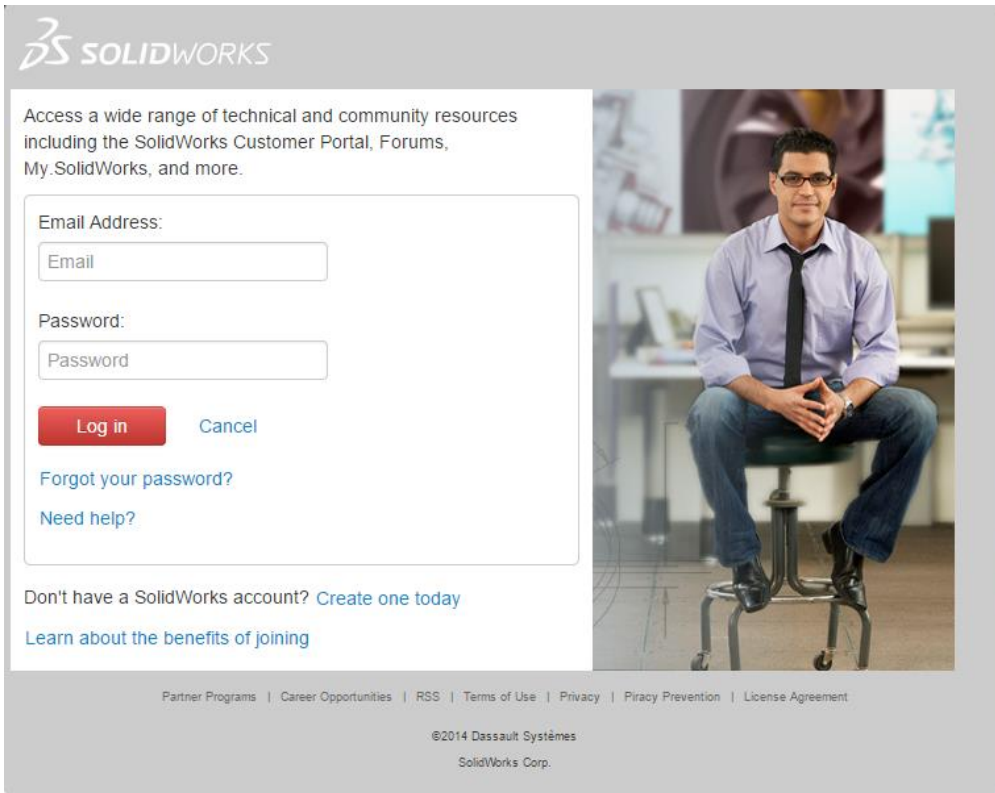

### STEP 3

Once you're logged in, you will get an Activation Code for DriveWorksXpress.

#### SOLIDWORKS 2015 DriveWorksXpress

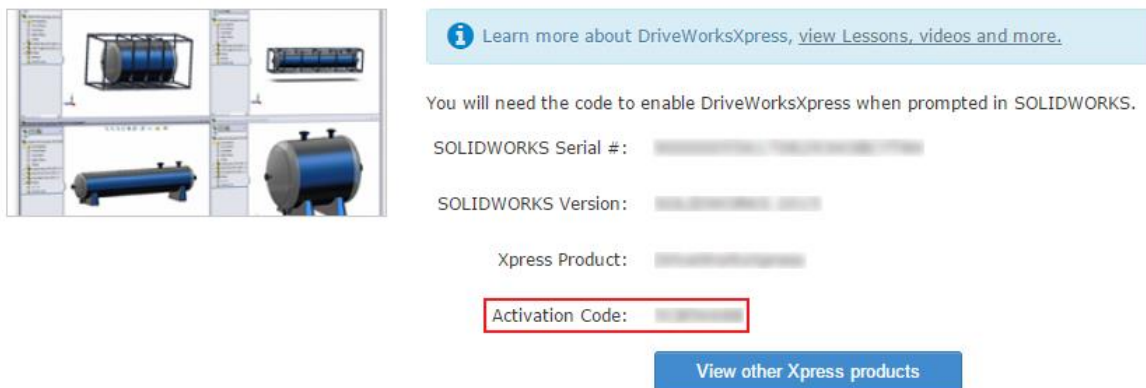

Copy the Activation Code and return to SOLIDWORKS.



Paste the code into the activation window and click OK.

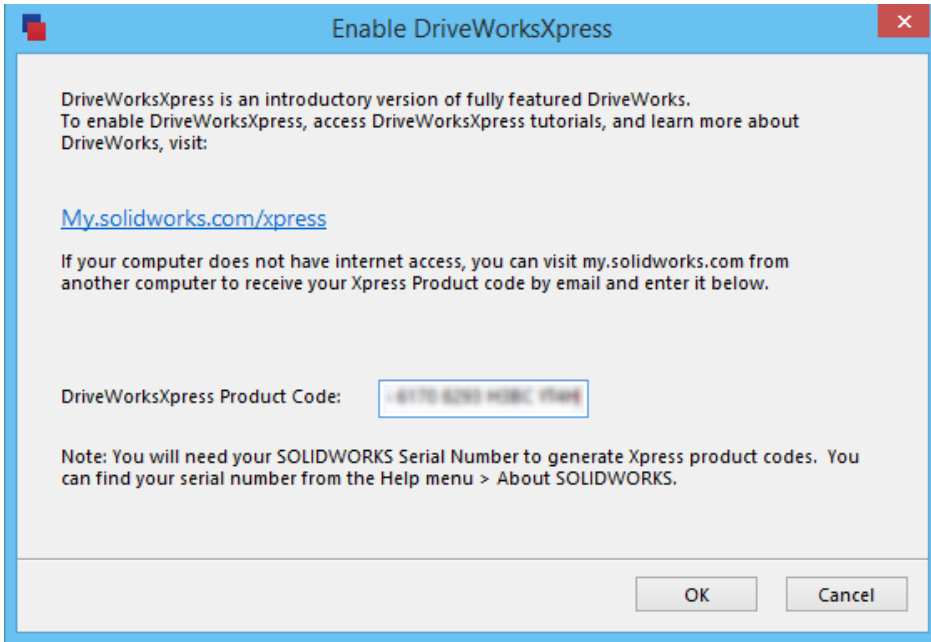

DriveWorksXpress will be activated and the task pane will open.  
You're now ready to automate your designs with DriveWorksXpress!

## BASIC SETUP

### LAUNCHING DRIVEWORKSXPRESS

Click on the 'Tools' tab in the SOLIDWORKS menu bar and select DriveWorksXpress from the drop-down options.

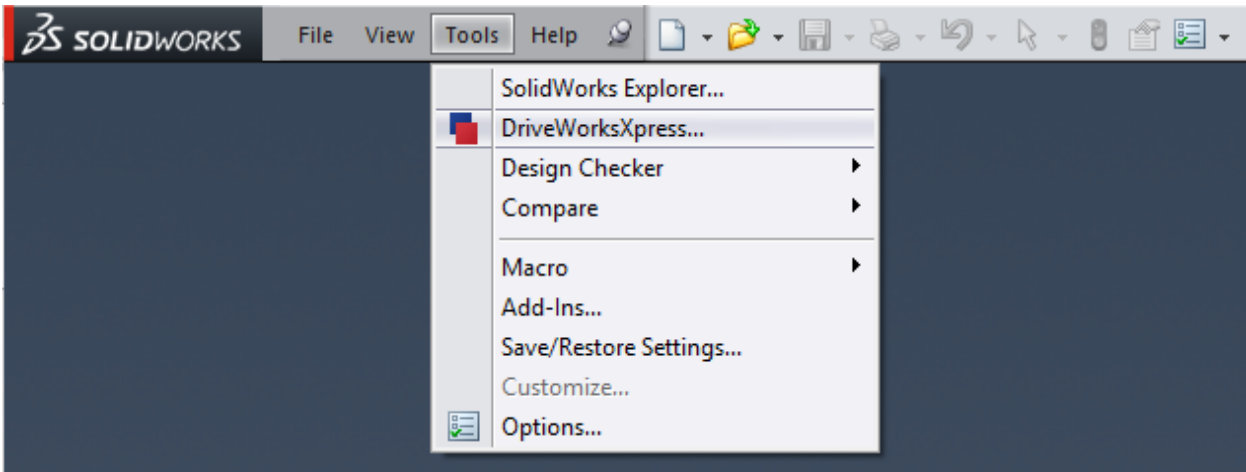

This activates DriveWorksXpress, which will open on the right hand side of the screen.

The DriveWorksXpress Welcome Page gives you three options:

- **Create / Change Database**  
This allows you to create a new project or load and change an existing project
- **Add / Edit Models**  
Add more models to the existing project
- **Run Models**  
Jump directly to Run to specify a new variation using a completed project

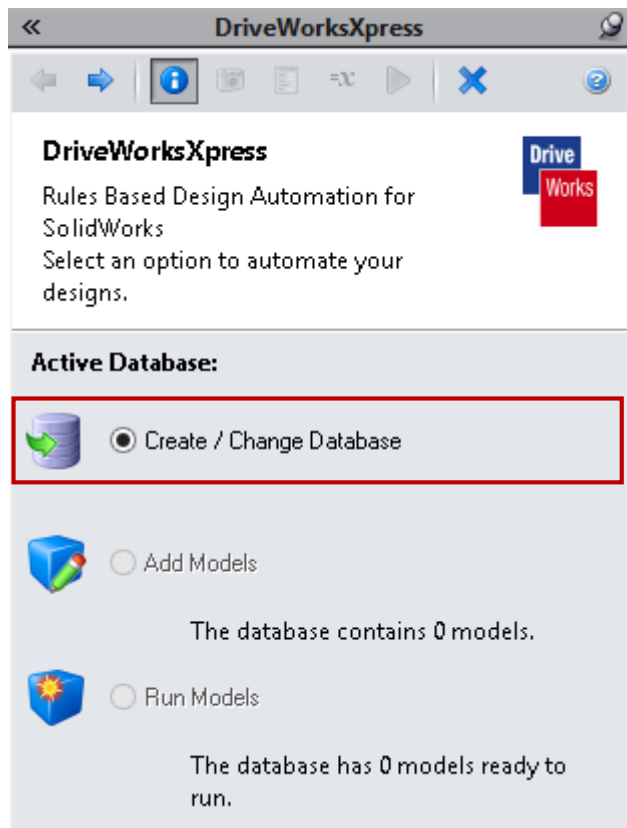

## CREATE A NEW DATABASE

To create a new database, click the 'Create / Change Database' radio button.

Click 'Next' at the top of the DriveWorksXpress Task Pane.

You will automatically be asked to open a new database.

Browse to a specific location on your hard drive where you would like your database to be saved and name your new project 'Conveyor'.

Click 'Open' to continue.

A database will be been created and saved in your specified location.

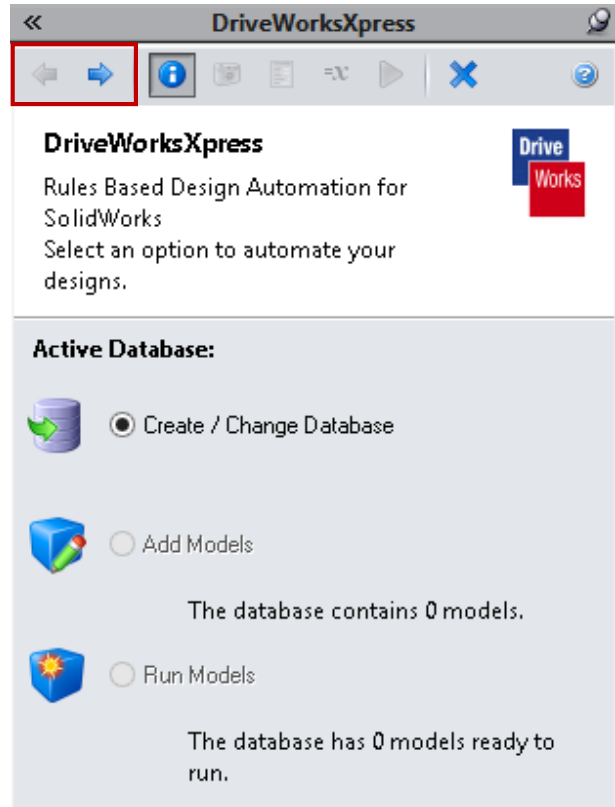

## CAPTURING MODELS AND DIMENSIONS

### CAPTURING SOLIDWORKS MODELS

Click 'Next' to navigate to the next window within the DriveWorksXpress Task Pane.

This will allow you to capture your models and the parameters that will be controlled. There are three ways to select which models are to be captured and driven using DriveWorksXpress:

- **Browse for new model**

If no models are open in SOLIDWORKS, you can browse to the location of the files you would like to be driven and automated using DriveWorksXpress

- **Use current open model**

If you currently have a part or assembly open in SOLIDWORKS, DriveWorksXpress can capture these models to be driven and automated

- **Models already in DriveWorksXpress**

If you have previously captured models within DriveWorksXpress, these will be displayed in the DriveWorksXpress Task Pane

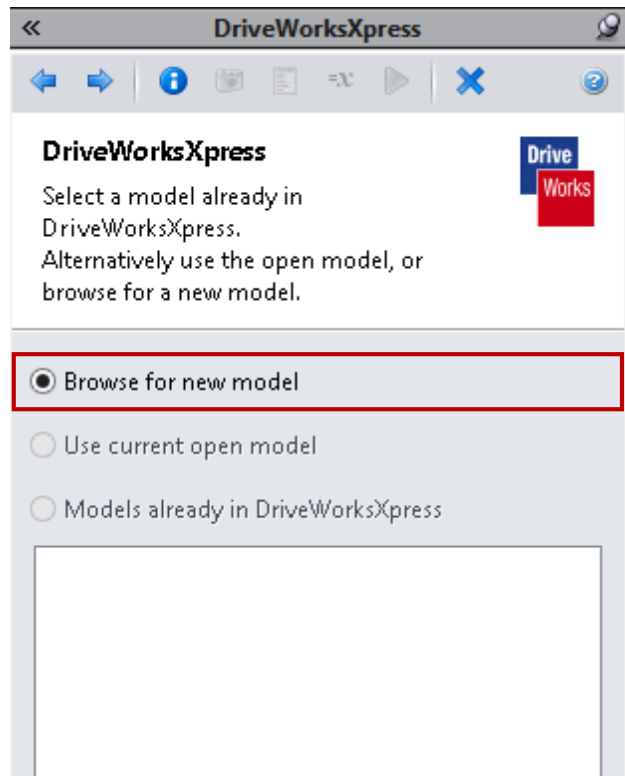

Make sure 'Browse for new model' is selected and click 'Next'.

Browse to the location on your hard drive where you have saved your Conveyor Base files, open the folder and select the SOLIDWORKS assembly called 'Conveyor Base Assembly.SLDASM'.

Click 'Open'.

The Conveyor Base Stand assembly will now open in SOLIDWORKS.

Once DriveWorksXpress knows the location of the files, we'll need to tell it which components we want to capture dimensions and features from.



The DriveWorksXpress Task Pane will now show all of the options for capturing model information.

**NOTE** – It is possible for these tabs to be dragged and compressed into one line in order to create more work space in DriveWorksXpress.

So don't worry if you don't see the tabs displayed in the image above. It is possible that you may see the following at the bottom of the Task Pane:



- **Captured Models**

This shows the models that have been captured inside of DriveWorks.

- **Captured Assembly Structure**

This allows you to see all the models making up the structure of the assembly within a 'tree' formation. This option allows you to select which models within the assembly that you would like to capture.

- **Dimensions and Features**

Dimensions and features can be controlled by double clicking a model from the model list within the model tree above the Capture options and then clicking 'Dimensions and Features'.

- **Custom Properties**

Any custom property that has been assigned in SOLIDWORKS can be captured and driven by DriveWorksXpress.

- **Drawings and Configurations**

If there are manufacturing drawings, they can be located and added to DriveWorksXpress by selecting this tab and hitting 'Browse' under the 'Drawings' heading.

If rules are required to drive which configuration of a part or assembly gets used, this can also be indicated in the 'Drawing and Configurations' option.

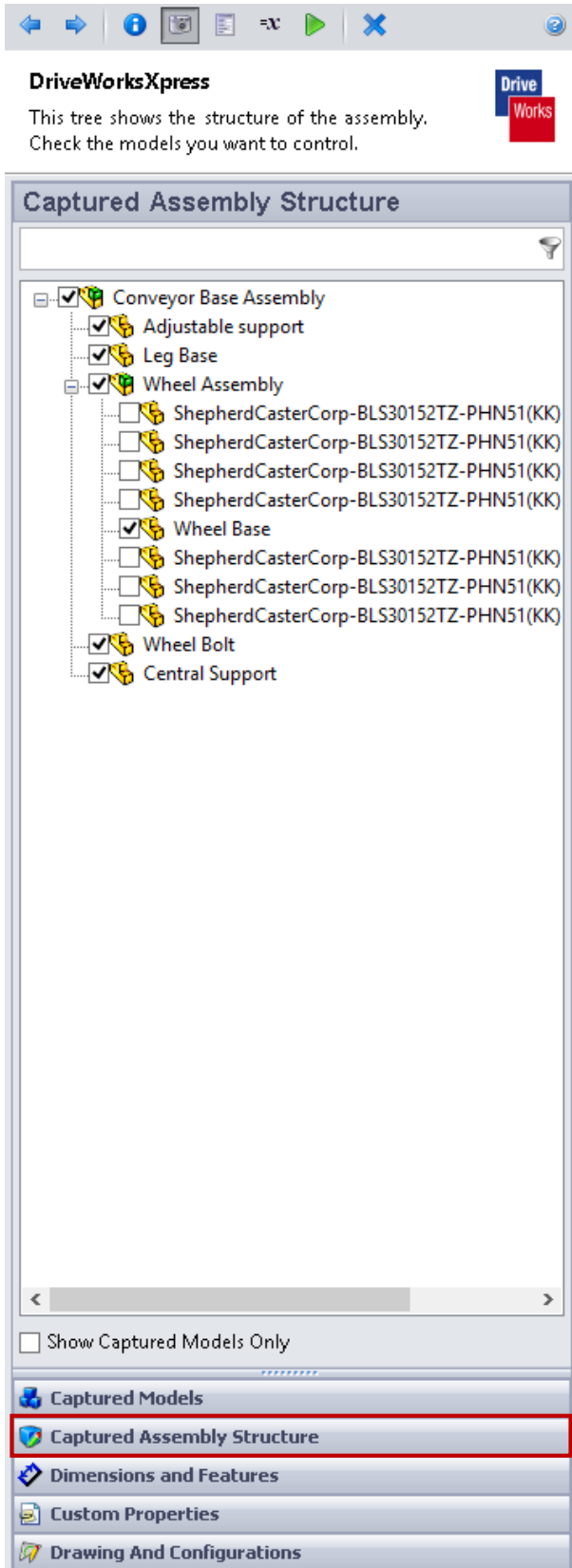

At the bottom of the Task Pane, select the 'Captured Assembly Structure' tab. This will display check boxes next to each model in the assembly. Select the parts/assemblies that you want DriveWorksXpress to control by checking the box next to each item.

The top level assembly (Conveyor Base Assembly) will already be checked. In this exercise we'll also control the following parts:

- Leg Base
- Adjustable Support
- Wheel Assembly Wheel Base
- Central Support
- Wheel Bolt

Capture the models that have been checked in the image.

## CAPTURING DIMENSIONS AND FEATURES

The Dimensions and Features tab allows you to choose which parameters from a model or assembly you would like to capture and drive. You can then assign a descriptive name to the dimension or feature you have selected to make them easier to identify and create rules for.

A parameter is captured by selecting the 'Captured Models' tab and then double clicking on the model that the parameter exists in.

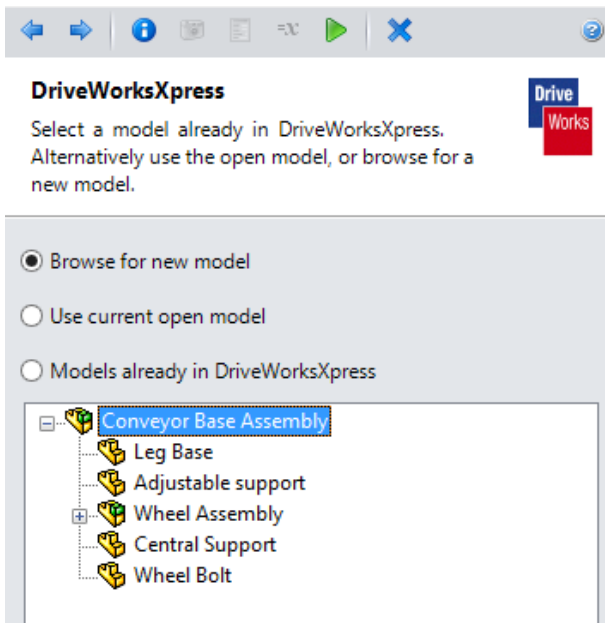

This will open the model in SOLIDWORKS allowing you to select the dimensions and features you wish to capture and control.

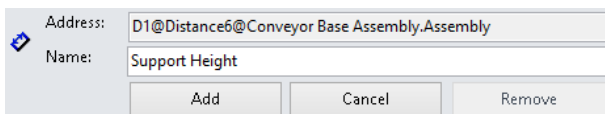

With the models captured, begin the process of capturing the parameters that you need to control. The following steps will guide you through the process of capturing dimensions and features in DriveWorksXpress.

## CAPTURING THE CONVEYOR BASE

With the Conveyor Base assembly open, click on the 'Dimensions and Features' tab in the DriveWorksXpress Task Pane.

Using the SOLIDWORKS Feature Tree that is displayed on the left hand side of the screen, select the 'Mates' branch and double click the feature called 'Distance6'.

Select the dimension of '100' that appears on the model.

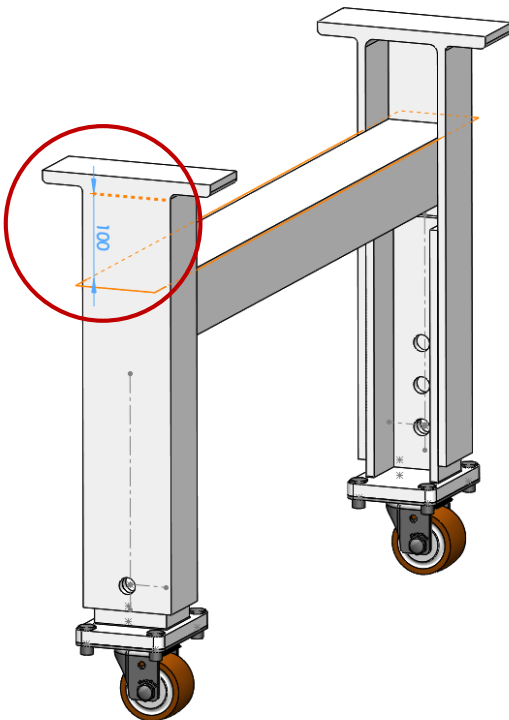
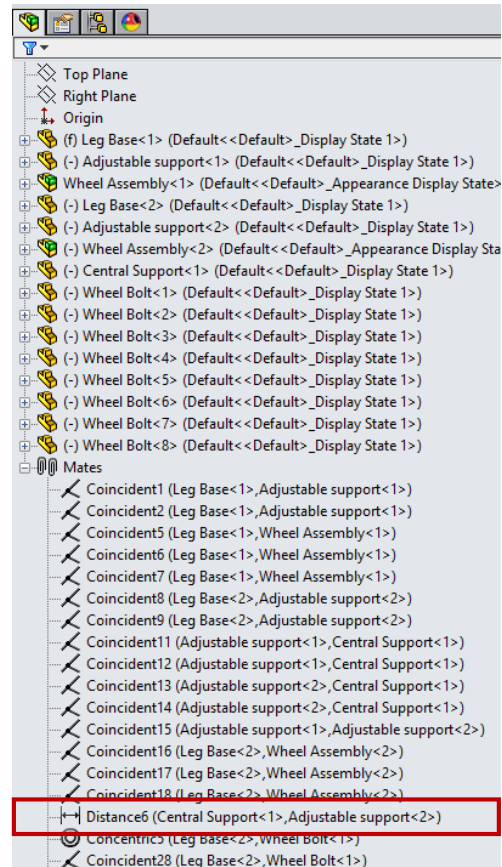



In the DriveWorksXpress Task Pane, rename the dimension 'Support Height'.

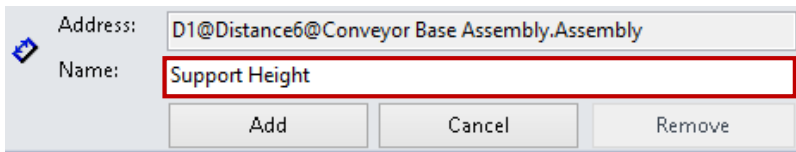

The screenshot shows a dialog box with a blue icon on the left. It contains two text input fields: 'Address:' with the value 'D1@Distance6@Conveyor Base Assembly.Assembly' and 'Name:' with the value 'Support Height'. The 'Name:' field is highlighted with a red border. Below the fields are three buttons: 'Add', 'Cancel', and 'Remove'.

Click 'Add'.

The captured dimension will be listed under Dimensions and Features in the DriveWorksXpress task pane.

The next step is to capture the rest of the features and dimensions from each individual part of the Conveyor Base assembly.

## CAPTURING THE WHEEL BASE

Navigate back to the original Conveyor Base assembly window in SOLIDWORKS by clicking 'Back' or by clicking 'Captured Models'.

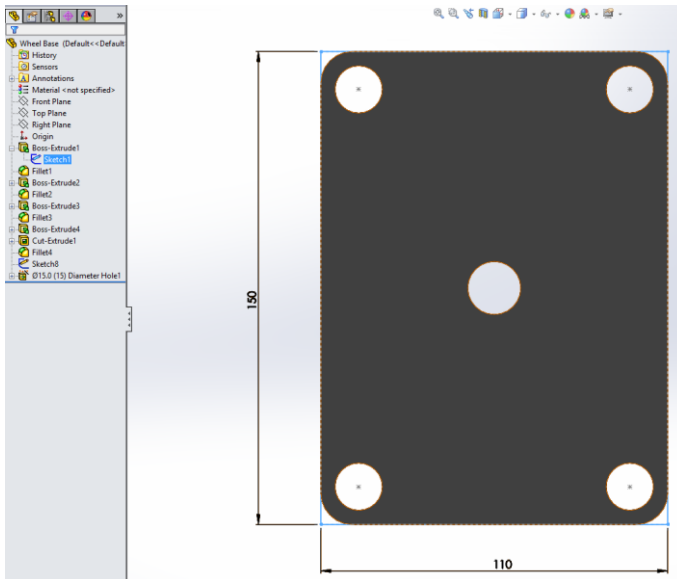

Double click the 'Wheel Base' model to open it within SOLIDWORKS.

Click the 'Dimensions and Features' tab.

The dimensions required on this particular model are the width and depth of the piece.

These can both be attained by clicking the feature named 'Boss-Extrude 1' from the SOLIDWORKS Feature Tree.

Select the dimension of '150'.

In the DriveWorksXpress Task Pane, name the dimension 'Wheel Base Depth'.

Click 'Add'.

Next, select the dimension of '110' which appears on the Wheel Base model when 'Boss-Extrude 1' is double clicked.

Name this 'Wheel Base Width'.

Click 'Add'.

## CAPTURING THE ADJUSTABLE SUPPORT

In the 'Captured Assembly Structure' tab, double click the 'Adjustable Support' model.

Capture the following dimensions within the model as previously demonstrated above:

Feature Name	Dimension Value	DriveWorks Name	Explanation
<b>Boss-Extrude 1</b>	500	AS Inside Height	Controls the height of the adjustable support
<b>Boss-Extrude 1</b>	90	AS Inside Width	Controls the width of the adjustable support
<b>Boss-Extrude 1</b>	70	AS Inside Depth	Controls the depth of the adjustable support
<b>Boss-Extrude 1</b>	10	AS Thickness	Controls the thickness of the material being used
<b>Boss-Extrude 2</b>	15	AS Top Plate Thickness	Controls the thickness of the Top Plate
<b>Boss-Extrude 2</b>	50	AS Top Plate 1	Controls the length of Top Plate 1
<b>Boss-Extrude 2</b>	50	AS Top Plate 2	Controls the length of Top Plate 2

## CAPTURING THE LEG BASE

In the 'Captured Assembly Structure' tab, double click the 'Leg Base' model.

Capture the following dimensions within the model as previously demonstrated:

Feature Name	Dimension Value	DriveWorks Name	Explanation
Boss-Extrude 1	150	Base Depth	Controls the depth of the base
Boss-Extrude 1	110	Base Width	Controls the width of the base
Boss-Extrude 1	15	Base Thickness	Controls the thickness of the base material
Boss-Extrude 3	300	Stand Height	Controls the height of the stand
Boss-Extrude 3	70	Stand Inner Width	Controls the width of the stand
Boss-Extrude 3	60	Stand Depth	Controls the Depth of the stand
Boss-Extrude 3	10	Stand Thickness	Controls the thickness of the stand material
LPattern2	50	Adjustment Hole Distance	Controls the distance between each of the 3 adjustment holes

## CAPTURING THE CENTRAL SUPPORT

In the 'Captured Assembly Structure' tab, double click the 'Central Support' model.

Capture the following dimensions within the model as previously demonstrated:

Feature Name	Dimension Value	DriveWorks Name	Explanation
Boss-Extrude 1	900	Central Support Length	Controls the length of the support
Boss-Extrude 1	90	Central Support Width	Controls the width of the support
Boss-Extrude 1	80	Central Support Depth	Controls the depth of the support
Boss-Extrude 1	10	Central Support Thickness	Controls the thickness of the support material

## CAPTURING DRAWINGS

With DriveWorksXpress you can capture your SOLIDWORKS engineering drawings. This feature means that when a new version of the model is made using DriveWorksXpress, the engineering drawing of that component is also updated to match it.

To add a drawing, open the model or assembly using the tree view in the Captured Models tab and then browse to the Drawings and Configurations tab. Click the 'Browse' button to search your hard drive for the corresponding SOLIDWORKS drawing file.

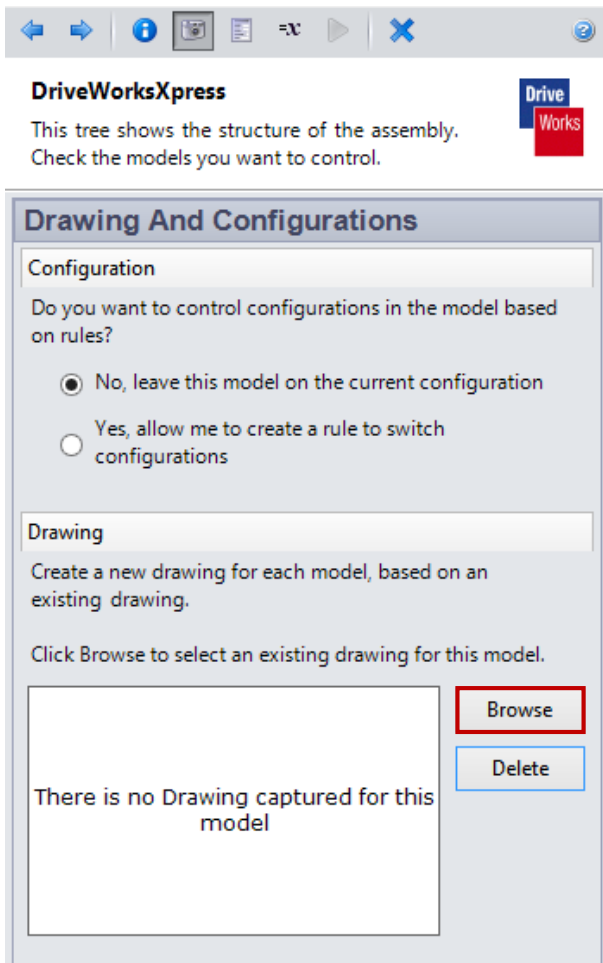

**Open the Adjustable Support model and browse for the drawing 'Adjustable Support.SLDDRW'.**

**Click 'Open' to capture the drawing.**

**Repeat this process for the following drawings:**

- **Leg Base**
- **Wheel Base**
- **Central Support**

It is possible to add one drawing per part or assembly.

The captured drawings will be updated and saved with a new name every time a specification is run.

## CREATING INPUT FORMS

In DriveWorksXpress you can create an input form for entering the values for your new parts and drawings. This form can be used again and again to specify and generate all the new parts and drawings, based on the rules you set and values you enter.

## ADDING CONTROLS

To access the Form Designer, click the 'Next' arrow at the top of the DriveWorksXpress Task Pane, or select the Form Creation Icon shown below.

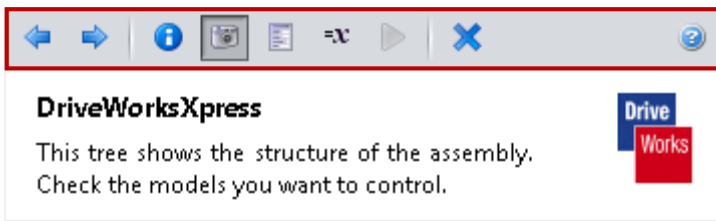

Each control requires three things:

- **Name** - You must provide a descriptive name for the form control. This name will be the title the user sees as they fill in your form i.e. Customer Name
- **Type** - Choose from five types of controls (inputs)
  - Text Box:** Input text directly by typing
  - Numeric Text Box:** Input numeric values and specify a minimum and maximum value
  - Drop Down:** Provides a list of options to choose from
  - Spin Button:** Users can select from a range of numeric values. A maximum and a minimum value, as well as the incremented value
  - Check Box:** Places a checkbox on the form
- **Required** - Enforces a value to be entered

In this example, a Customer Name and Order Number will be created. This can be done using a Text Box. Later we will build a rule to append the Customer Name and Order Number to each set of new files in a specification so it can be easily identified.

Begin by adding a Text Box to the Form to allow a Customer Name to be entered.

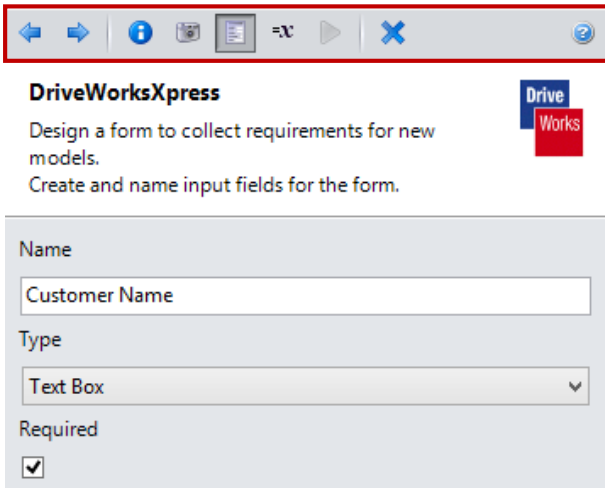

**Add a new Text Box called Customer Name:**

Control Name	Control Type	Required
Customer Name	Text Box	Yes

**Type the name of the Control and then use the Drop Down to select the Control Type.**

**Tick the 'Required' check box to ensure a Customer Name is entered for each new specification.**

**Click 'Next' to register the control and display the Control List.**

Notice that the form control appears in the form designer within the DriveWorksXpress Task Pane. As you create your form, you can edit and delete controls, as well as change the order by using the Up and Down arrows.

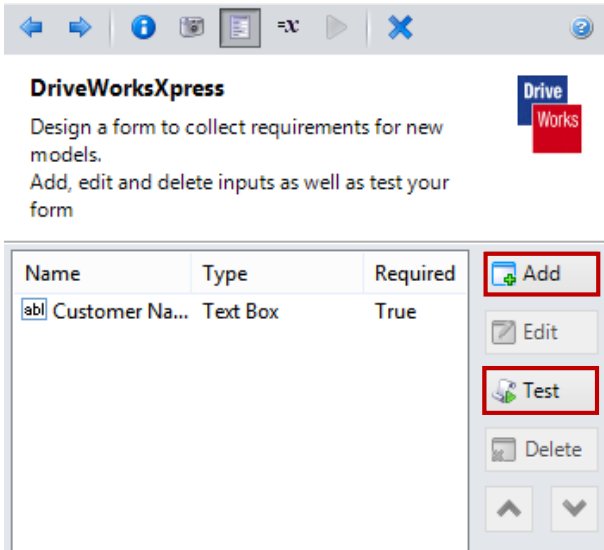

You can also test your form by clicking 'Test'.



Click 'Add' and repeat the steps to add the following controls:

Add a new Text Box called Order Number:

Control Name	Control Type	Required
Order Number	Text Box	Yes

To specify most dimensions within the model, you will need to use Numeric Text Boxes. Numeric Text Boxes allow a maximum and a minimum value to be enforced. Use the Numeric Text Box control for the inputs shown in the table below.

Add the controls listed in the table below:

Control Name	Type of Control	Required?	Min Value	Max Value
Height of Frame	Numeric Text Box	Yes	500	1200
Width of Base Stand	Numeric Text Box	Yes	60	100
Depth of Base Stand	Numeric text Box	Yes	40	90
Overall Width	Numeric Text Box	Yes	600	1400
Length of Top Plate	Numeric Text box	Yes	100	400

To allow a user to see an entire range of options available for a particular input, a Spin Button can be used.

**Add a new Spin Button called Thickness of Material:**

Control Name	Type of Control	Required?	Min Value	Max Value	Increment
<b>Thickness of Material</b>	Spin Button	Yes	5	17	1

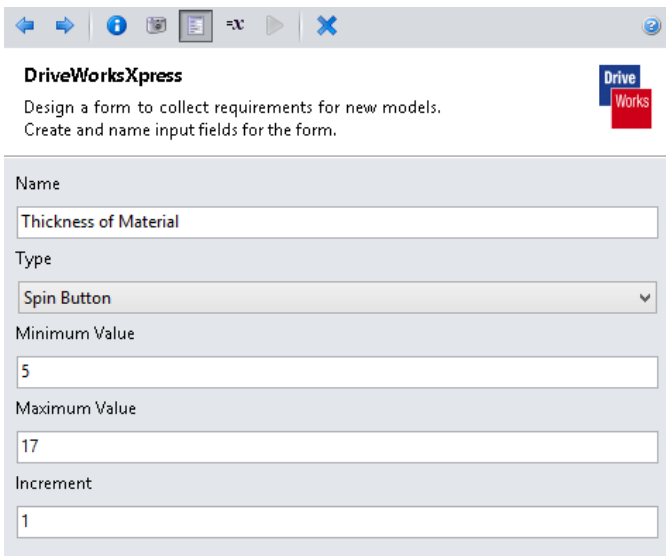

To allow a user to specify whether wheels are a necessary component of the conveyor belt base stand, the check box input can be used.

**Add a new Check Box called Wheels:**

Control Name	Type of Control	Required?
<b>Wheels</b>	Check Box	N/A

## TEST MODE

**DriveWorksXpress**  
Enter information to test the form.  
Click on Set Defaults to see the current values when you fill out the form.

**Conveyor Base Assembly**

Customer Name  
   
Type in a value for Customer Name

CB-

Height of Frame

Width of Base Stand

Depth of Base Stand

Overall Width

Length of Top Plate

Thickness of Material

Wheels

Clear Set Defaults

Click 'Test' within the Form Designer to preview the form you have created and test it out for yourself.

You will notice that as you fill out the forms with valid information, the background of the text boxes will change from pink to white and the yellow warning triangles will disappear.

If you hover over a control, information about the control will be shown in a tooltip.

It's good practice to set default values for controls. Setting default values makes building rules easier because the controls have values.

To set a default value, enter values into the form controls and click 'Set Defaults'.

## RULES BUILDER

DriveWorksXpress lets you use Excel syntax to build rules to automate your SOLIDWORKS models.

Navigate to the Rules tab by clicking 'Next' or 'Rules' in the DriveWorksXpress Task Pane.

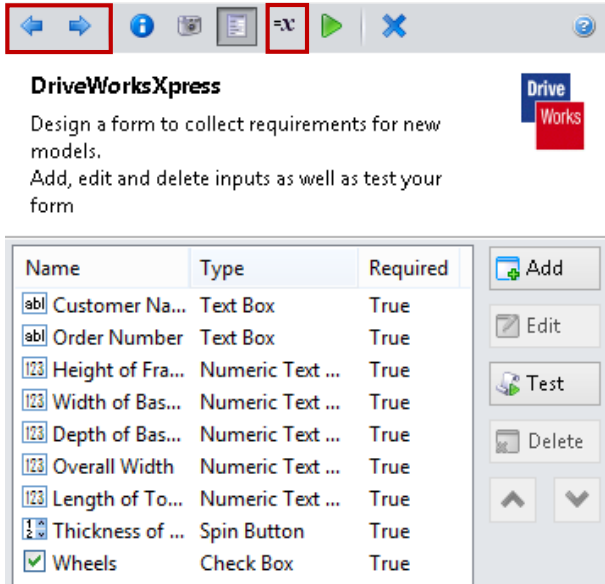

The Rules tab shows a summary of your rules and how many of each rule type there are. The summary also shows the number of unbuilt rules that must be completed before a new Specification can be created:

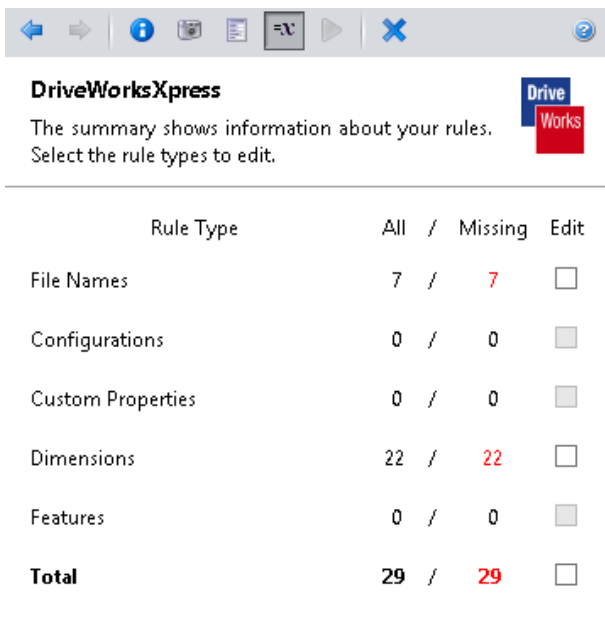

Selecting the check box against a Rule Type filters the rules by that type. It is possible to select more than one rule type at a time.

Filtering is helpful where there are large numbers of rules to be built. Where Rules are not required for a particular type, the check box will not be enabled.

The summary provides constant feedback on Total Number of Rules and Missing Rules (which still require rules to be built against them).

Before you begin to create rules within this tutorial, here is a quick summary of the DriveWorksXpress Rules Builder.

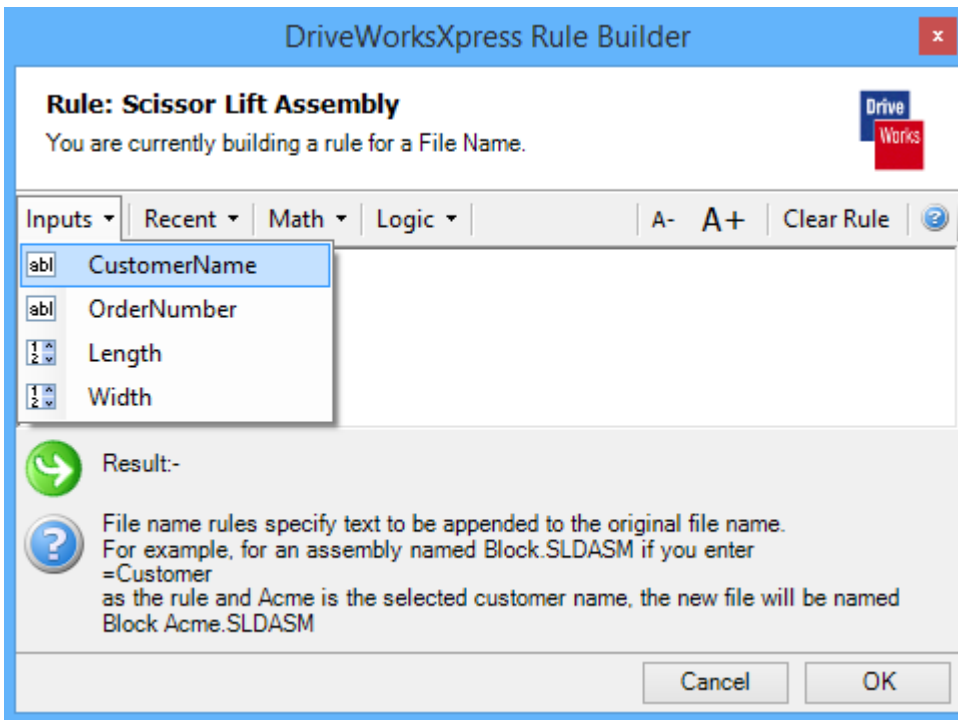

There are four drop-down menus within the DriveWorksXpress Rule Builder:

- **Inputs**  
Lists the available controls that can be used in rules
- **Recent**  
This can be populated with commonly used text strings or equations
- **Math**  
Mathematical operators (e.g. add, subtract, and divide)
- **Logic**  
Logical operators (e.g. IF, <, >, =)

## FILE NAME RULES

File Name rules allow different sets of files that are generated for each new specification of an automated design to be easily identifiable. Each of the files being driven will be for a unique project and therefore will require a unique set of file names.

**Check the File Name check box and click 'Next' in the DriveWorksXpress Navigation.**

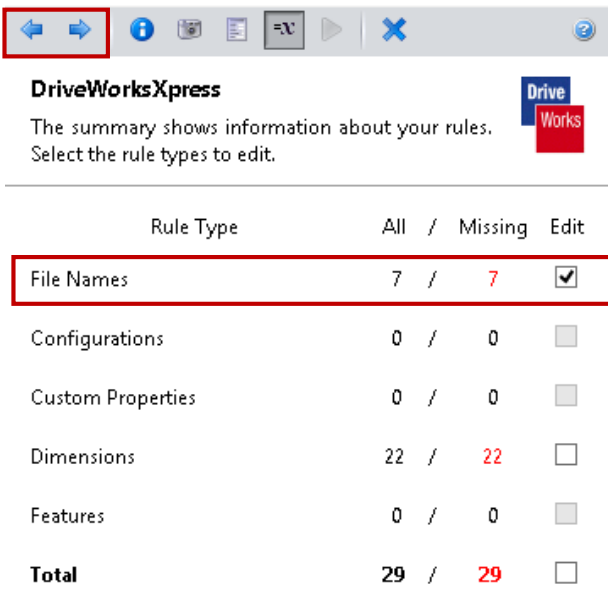

The captured components requiring a File Name rule will be listed.

You can choose to show all rules or just missing rules that have not been built yet. You also have the option to view your files as a List or in a Tree View. The default is List View.

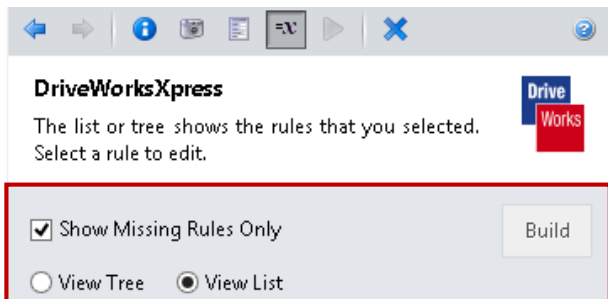

## BUILDING MULTIPLE FILE NAME RULES

To create the same rule for multiple models, select each model you wish to create the file name rule for while holding down the Ctrl key.

**Multi-select all models except 'Wheel Assembly' and 'Wheel Bolt' and click 'Build'.**

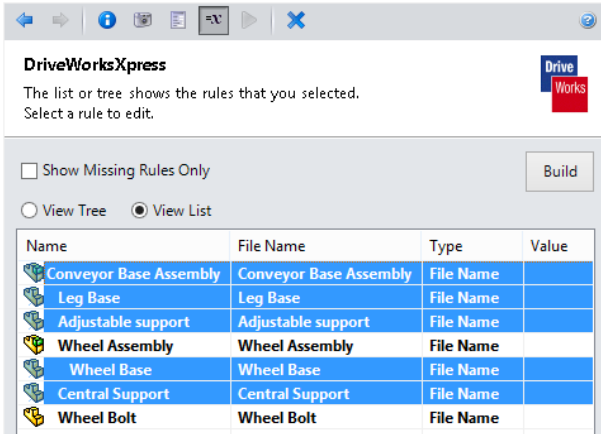

**The DriveWorksXpress Rules Builder will open.**

All the file names that are going to be created for these models will need to be unique to the particular specification and therefore the file names should be populated with information that will allow the files to be easily identified. For this tutorial, a unique file name will be created by using the customer's name and their order number.

The file name rules will have the format, "Component Customer Name – OrderNumber".

**Start by selecting the 'Customer Name' control from the Inputs tab.** This will now place the value from the control into the rule.

**To incorporate the hyphen between Customer Name and Order Number, ampersands (&) need to be used. This is because CustomerName is one string and the hyphen is another string. Therefore, you need to type & "-".**

The rule should now read: **CustomerName & "-"**

**To finish off the File Name rule, type & OrderNumber (or select 'OrderNumber' from the Input menu).**

The completed rule should read: **CustomerName & "-" & OrderNumber**

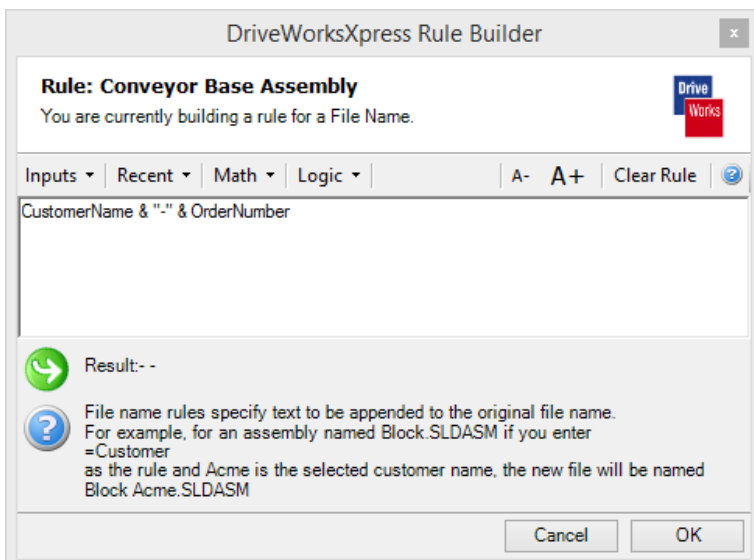

An example of this rule when put into practice will read:

"ConveyorBaseAssemblyCannedFoodsInc-DW006"

**Click 'OK' to save the file name rule for the selected models.**



## BUILD A RULE FOR THE WHEEL ASSEMBLY

There should only be two models remaining which still require file name rules. The 'Wheel Assembly' and 'Wheel Bolt' rules will differ from the other model file name rules, as they will be based around a logic function. The file name rules for these two models will allow the 'Wheel Assembly' and 'Wheel Bolt' files to be saved if wheels are specified as being required within the form user's specification.

**Click 'Wheel Assembly' and then 'Build' to take you back into the DriveWorksXpress Rules Builder.**

**In the 'Logic' tab, select the 'IF ( , , )' function build the following file name rule:**

File Name	Rule
<b>Wheel Assembly</b>	IF(Wheels = TRUE, CustomerName & "-" & OrderNumber, "Delete")

This rule ensures that if the user ticks the check box to add wheels to their conveyor belt base stand, then the Customer Name and Order Number will be appended to the file name of the generated models. If the 'Wheels' check box is not checked, the models will be deleted from the generated assembly.

## BUILD A RULE FOR THE WHEEL BOLT

This rule ensures that if the wheels are not specified in the form then the 'Wheel Bolt' model is not shown within the model and the 'Wheel Bolt' file is not saved for that project.

**Click 'Wheel Bolt' and build the following file name rule:**

File Name	Rule
<b>Wheel Bolt</b>	IF(Wheels = TRUE, CustomerName & "-" & OrderNumber, "Delete")

**Click 'Back' in the DriveWorksXpress navigation to return to the Rules Summary page.**

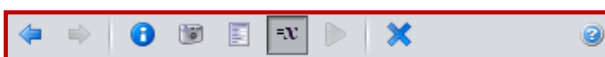

### DriveWorksXpress

The list or tree shows the rules that you selected.  
Select a rule to edit.



## DIMENSION RULES

Dimension rules allow you to automate your SOLIDWORKS models by taking information entered on the Form, calculating a result and then sending it to the SOLIDWORKS model. This allows you to control multiple dimensions at the same time using only a few inputs.

**Un-check 'File Names' and check 'Dimensions'. Click 'Next' in the DriveWorksXpress navigation.**

The tables below show the name of each dimension and the rule that should be created for that dimension.

**Build the following rules for the captured dimensions:**

Rule Name	Rule
AS Inside Height	= HeightofFrame – ThicknessofMaterial – ( ThicknessofMaterial * 1.5 ) – 20.245
AS Inside Width	= WidthofBaseStand
AS Inside Depth	= DepthofBaseStand
AS Thickness	= ThicknessofMaterial
AS Top Plate Thickness	= ThicknessofMaterial
AS Top Plate 1	= (LengthofTopPlate – ( WidthofBaseStand + ( 2 * ThicknessofMaterial ) ) ) / 2
AS Top Plate 2	= (LengthofTopPlate – ( WidthofBaseStand + ( 2 * ThicknessofMaterial ) ) ) / 2
Support Height	= ( ( HeightofFrame – ThicknessofMaterial – ( ThicknessofMaterial * 1.5 ) – 20.245 ) / 100 ) * 15
Base Depth	= DepthofBaseStand + ( 2 * ThicknessofMaterial ) + 40
Base Width	= WidthofBaseStand + ( 2 * ThicknessofMaterial ) + 40
Stand Inner Width	= WidthofBaseStand – ( 2 * ThicknessofMaterial )
Stand Depth	= DepthofBaseStand – ThicknessofMaterial
Stand Height	= ( HeightofFrame – ThicknessofMaterial – ( ThicknessofMaterial * 1.5 ) – 20.245 ) / 1.8
Stand Thickness	= ThicknessofMaterial
Wheel Base Width	= WidthofBaseStand + ( 2 * ThicknessofMaterial ) + 40
Wheel Base Depth	= DepthofBaseStand + ( 2 * ThicknessofMaterial ) + 40
Central Support Length	= OverallWidth – ( 4* ThicknessofMaterial )
Central Support Width	= WidthofBaseStand

<b>Central Support Depth</b>	= WidthofBaseStand / 2
<b>Central Support Thickness</b>	= ThicknessofMaterial
<b>Base Thickness</b>	= ThicknessofMaterial * 1.5
<b>Adjustment Hole Distance</b>	= ( (HeightofFrame – ThicknessofMaterial – (ThicknessofMaterial * 1.5) – 20.245) / 1.8) / 3

Click 'Back' to return to the Rules Summary page.

There are now 0 rules missing for the captured dimensions.

## RUNNING THE PROJECT

Click 'Next' or 'Run' in the DriveWorksXpress navigation, which will take you to the 'Run' Task Pane.

**DriveWorksXpress**  
Enter the required values in the form below.  
Complete the form to generate a new version of  
Conveyor Base Assembly.

Defaults Last Used

**Conveyor Base Assembly**

Customer Name

Order Number

Height of Frame

Width of Base Stand

Depth of Base Stand

Overall Width

Length of Top Plate

Thickness of Material  
5

Wheels

Clear Create

Now that all of the rules are written for the project, new specifications can be created.

Within the 'Run' task pane, you will be able to see the form controls you created earlier in the project.

Follow the control tool tips and complete the form.

All of the controls which require a value will appear with a pink background which will turn white once a suitable value is entered.

There are three methods of completing the Form. You can use the Defaults button to populate the controls with default values, Last Used button to use the last used values or enter new details.

Click 'Create'. DriveWorksXpress will now generate your new models and drawings.

A generation report is produced which shows activity on all of the driven values. Any errors will appear with a red cross, and all successful values will appear with a green tick.

To view the modified SOLIDWORKS Drawing File for this new model, open the folder where all the files have been saved to.



**Congratulations! You have now completed this DriveWorksXpress Tutorial.**

There is lots more downloadable content available at:

[www.driveworksxpess.com](http://www.driveworksxpess.com)

Now you've tried DriveWorksXpress, GO AUTOMATE your own SOLIDWORKS projects!